



 **NODOR**
always innovating

ES MANUAL DE INSTALACIÓN

EN INSTRUCCIONS FOR INSTALLATION

FR MANUEL D'INSTALLATION

PT MANUAL DE INSTALAÇÃO

DE MONTAGEANLEITUNG



ES IMPORTANTE - Por favor lea atentamente la guía de seguridad antes del uso.

EN IMPORTANT - Please read carefully the separate safety guide before use.



FR IMPORTANT - Lire attentivement le guide de sécurité avant utilisation.

PT IMPORTANTE - Por favor, leia o guia de segurança com cuidado antes de usa.



DE WICHTIG - Bitte lesen Sie die Sicherheitsanleitung vor dem Gebrauch sorgfältig durch.

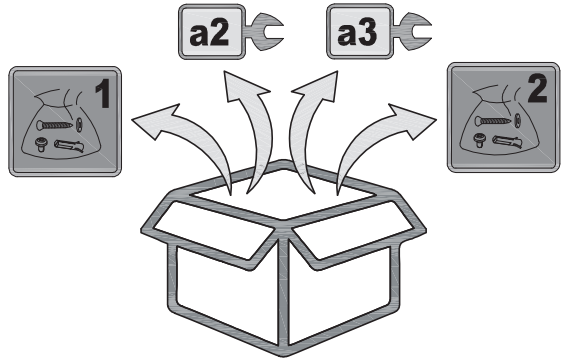

a1 X 1

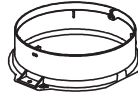

a4 X 4



a5 X 2



Ø3.9 x 13



a6 X 8



Ø3 x 8

a9 X 1



a7 X 6



Ø4.2 x 13

a10 X 1



a11 X 1



a2 X 1

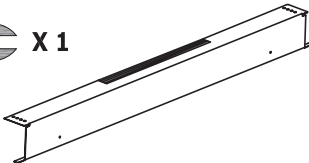

a3 X 1

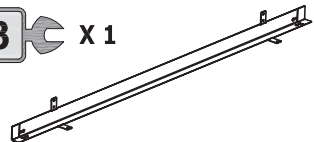

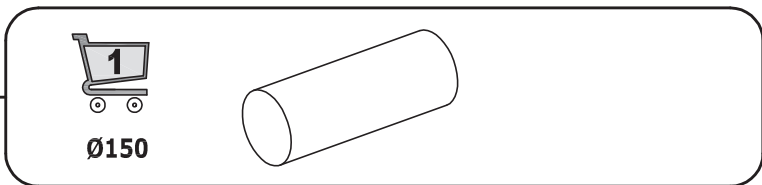
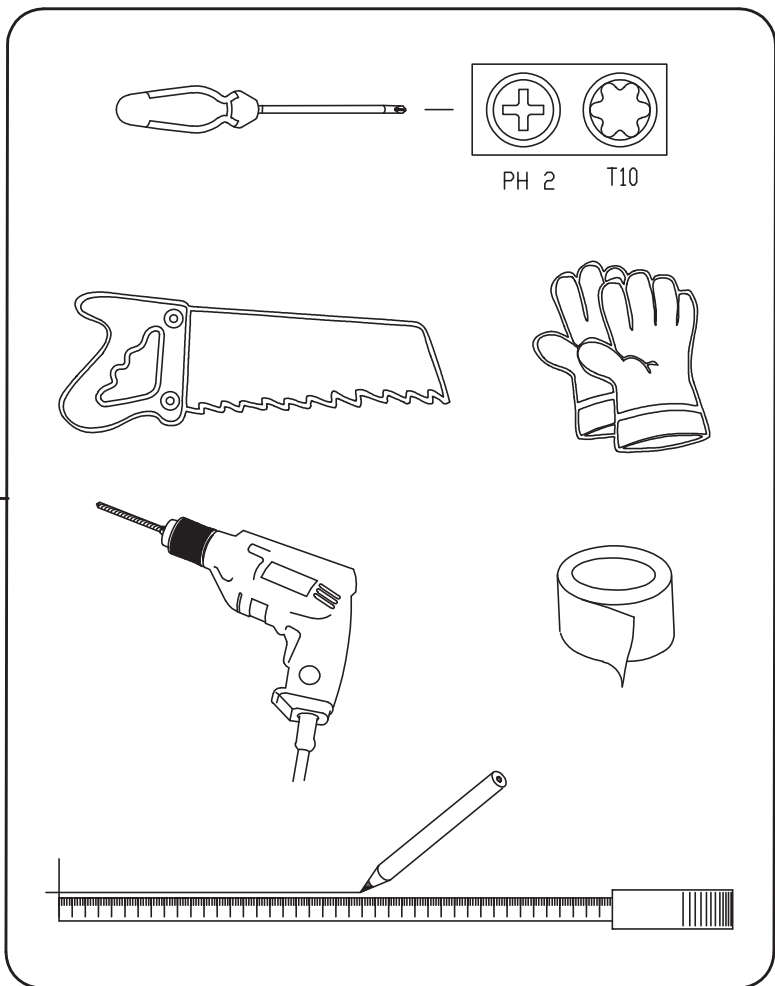

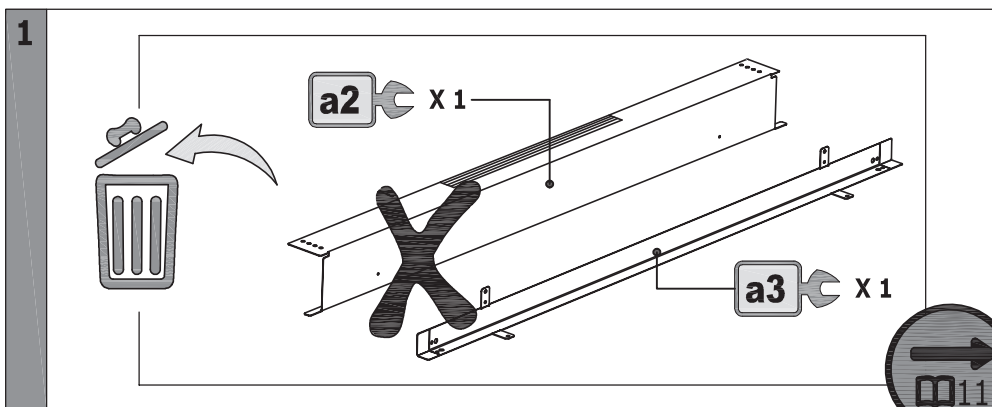
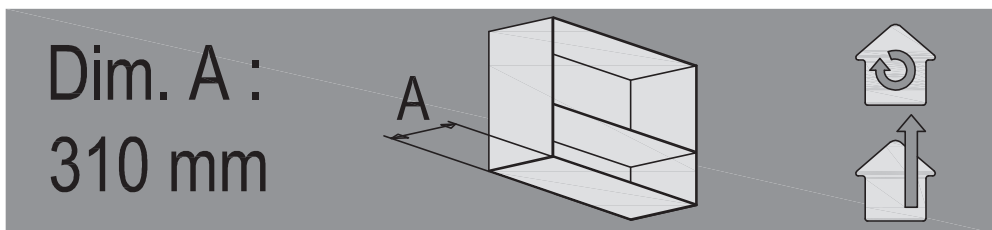
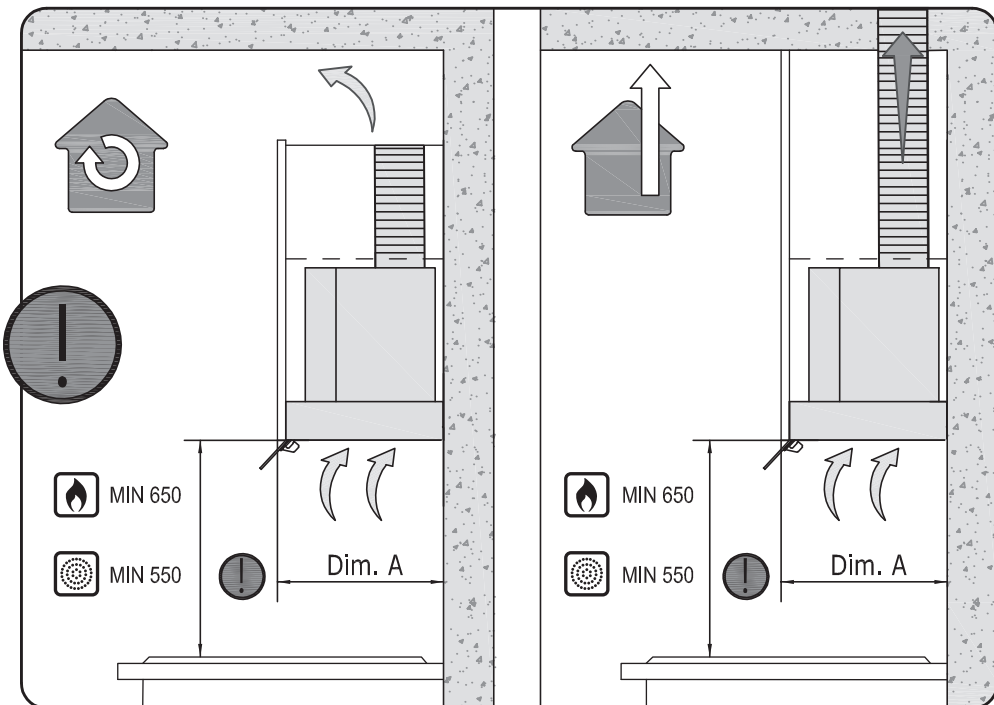

Dim. A :
320 mm

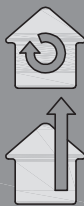
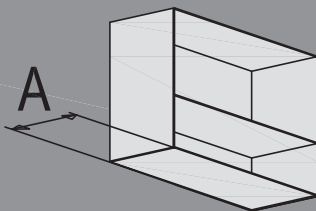

1

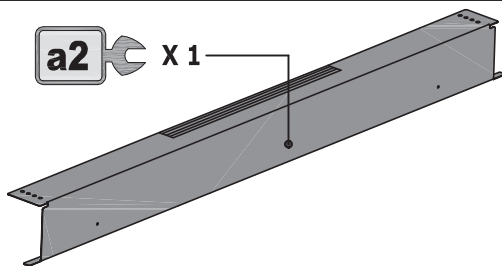
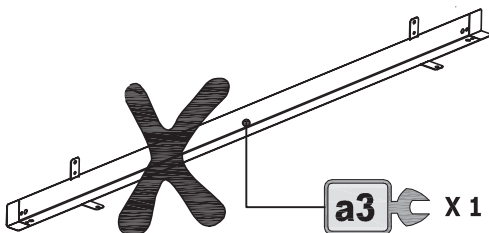
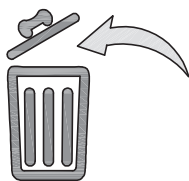

1.1

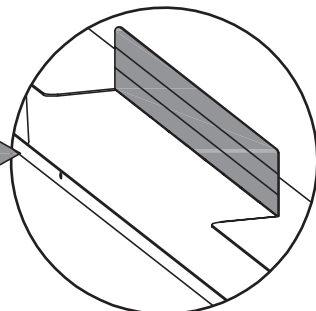
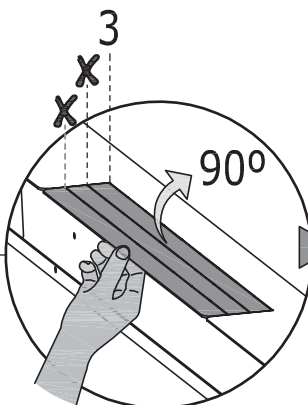
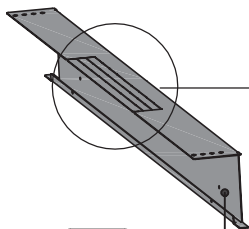

1.2

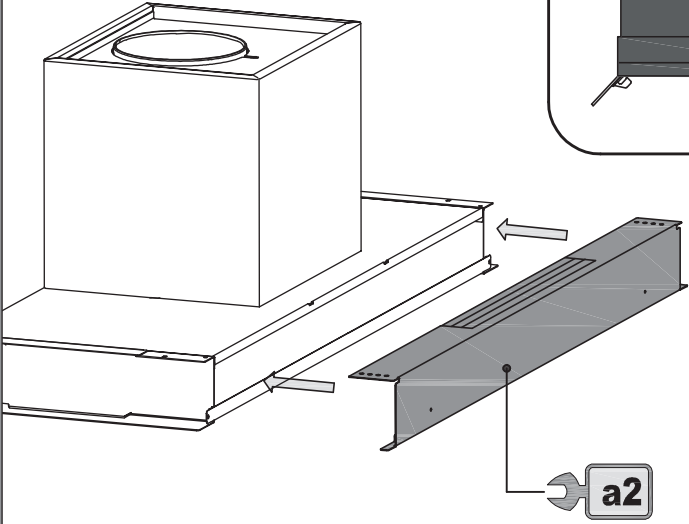
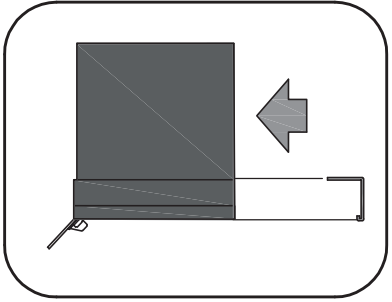

1.3

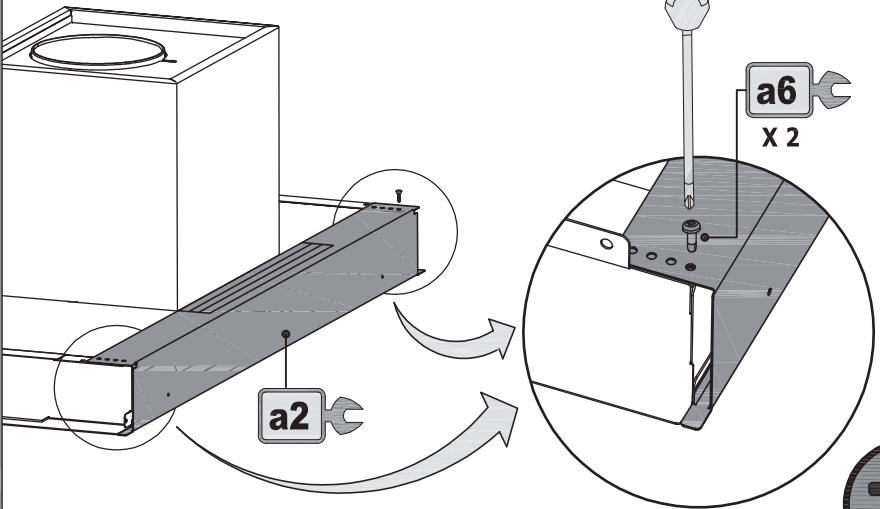

Dim. A :
330-340 mm

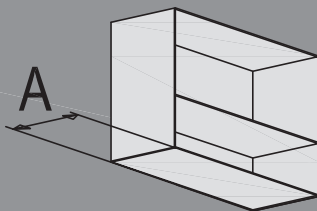

1

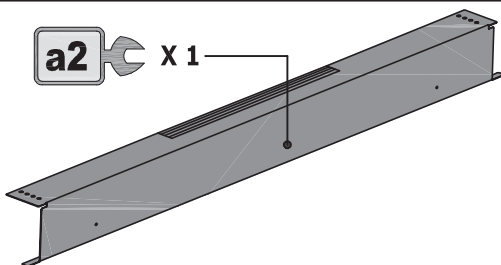
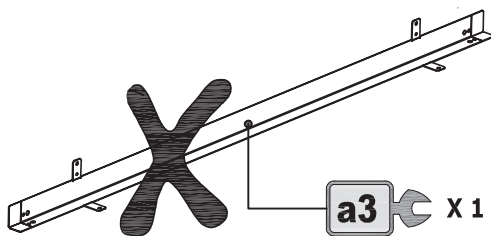
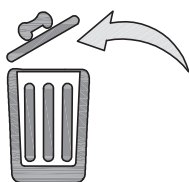

1.1

~~X~~ 2 ~~X~~
Dim A:
320 mm

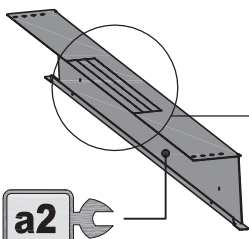

Dim A:
330 mm

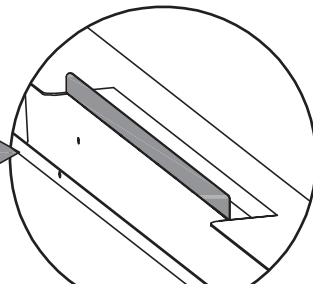
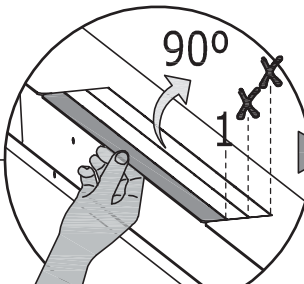
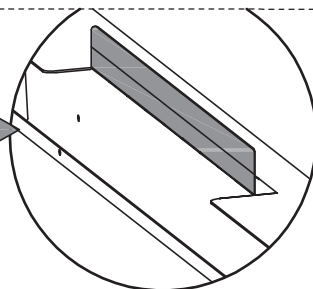
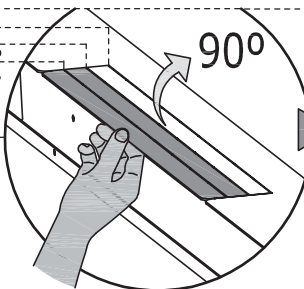

1

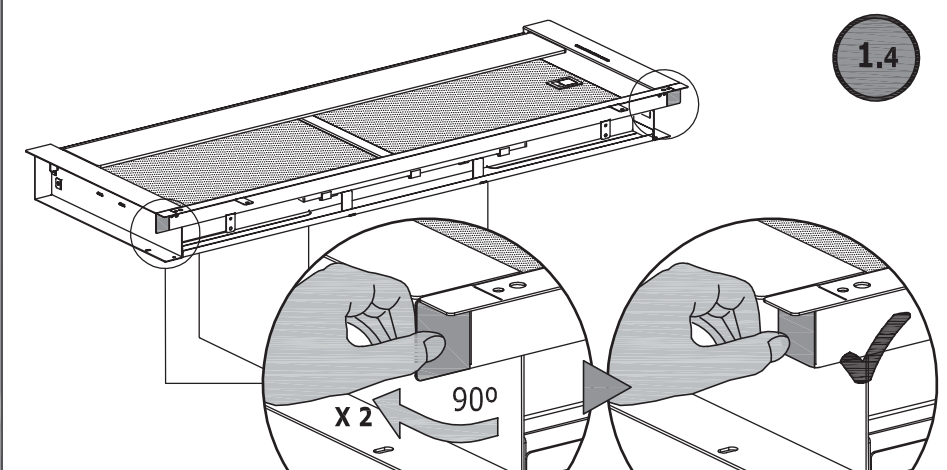
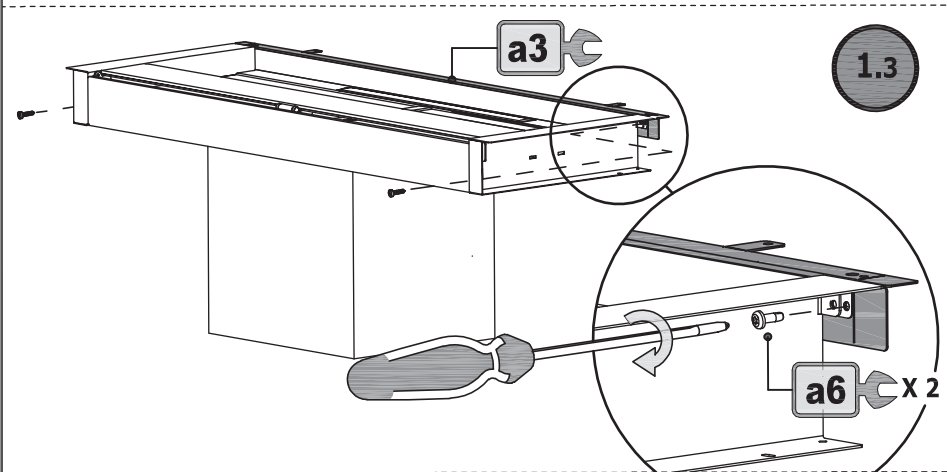
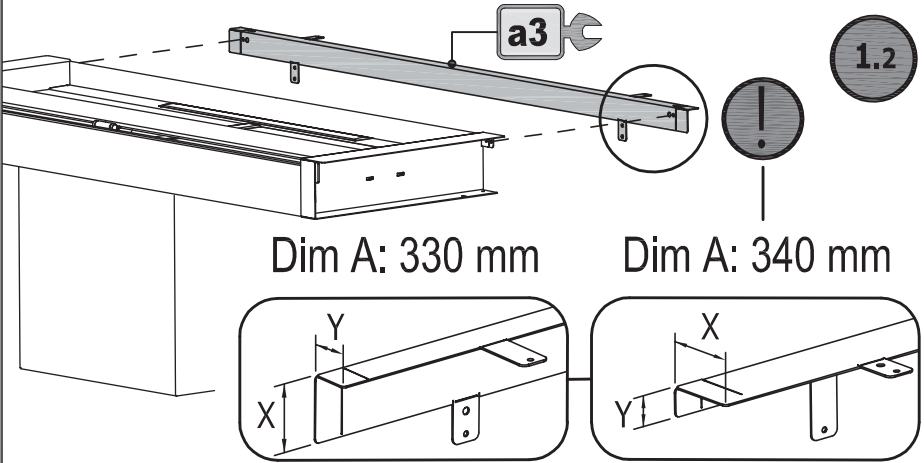

1.5

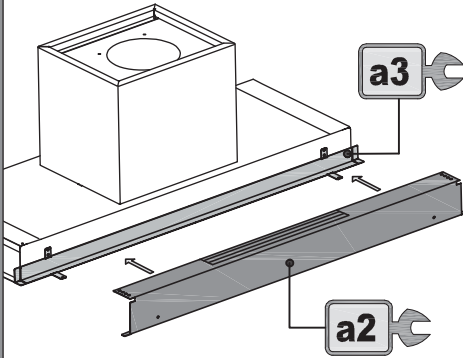
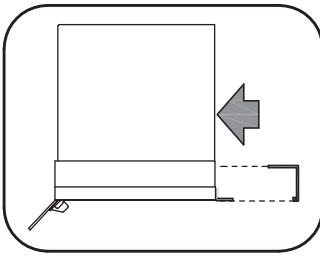

1.6

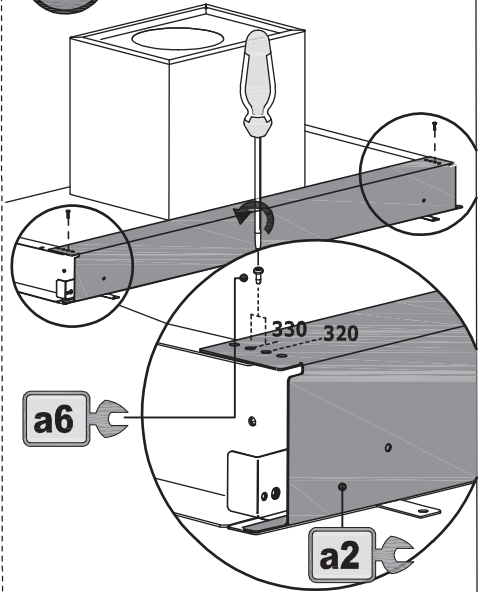

1.7

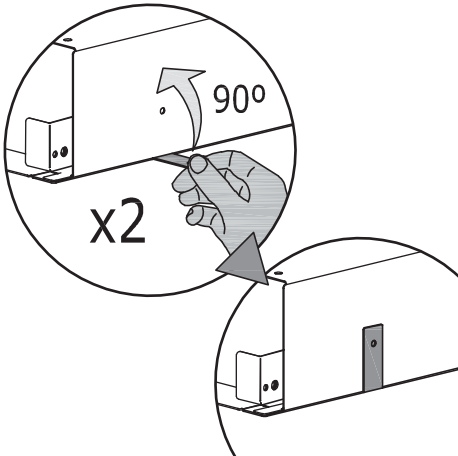
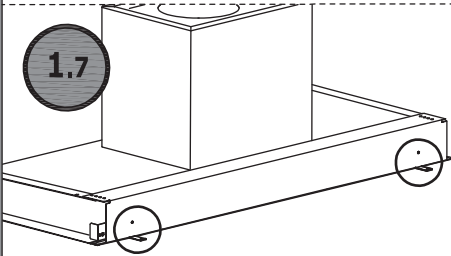

1.8

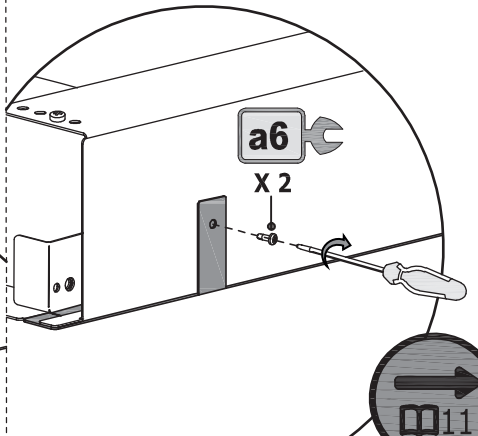
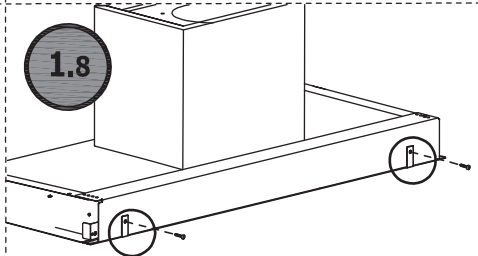

Dim. A :
350 mm

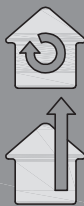
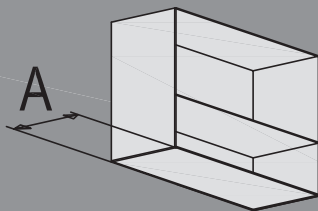

1

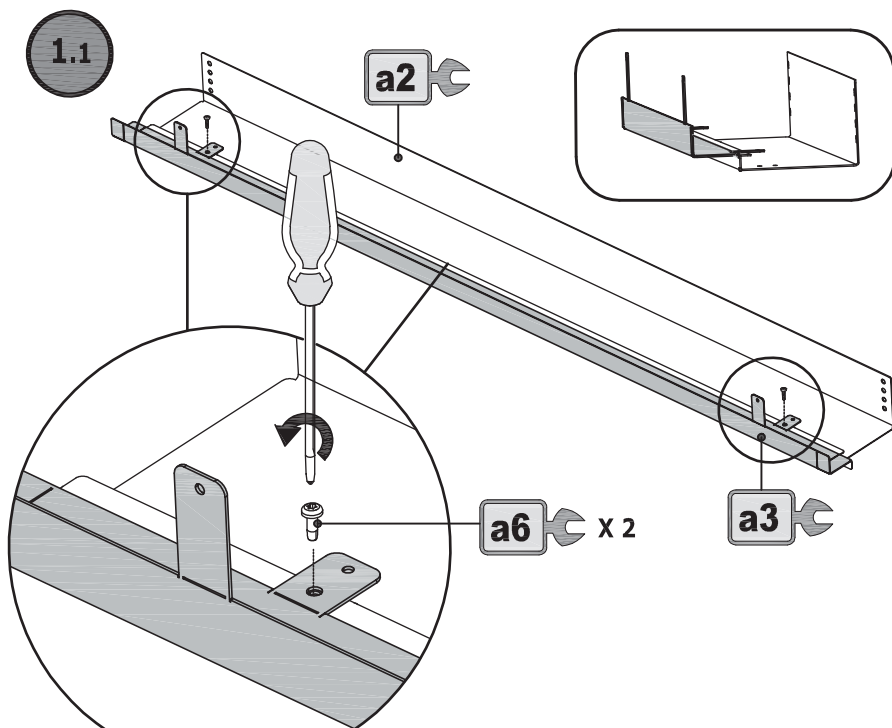
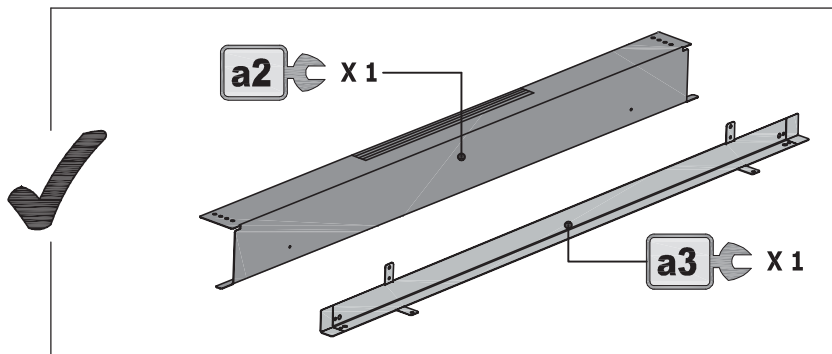

1

1.2

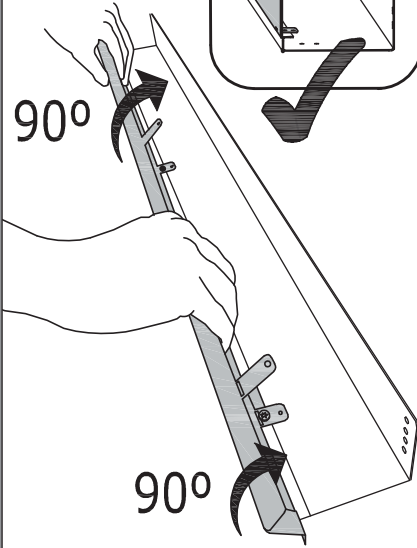

1.3

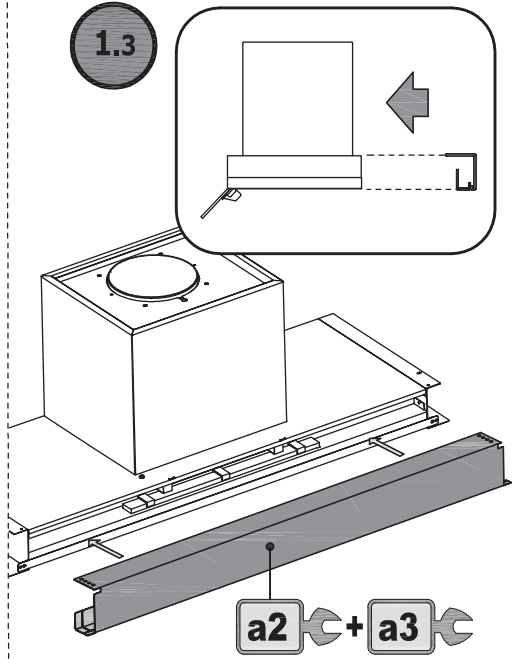

1.4

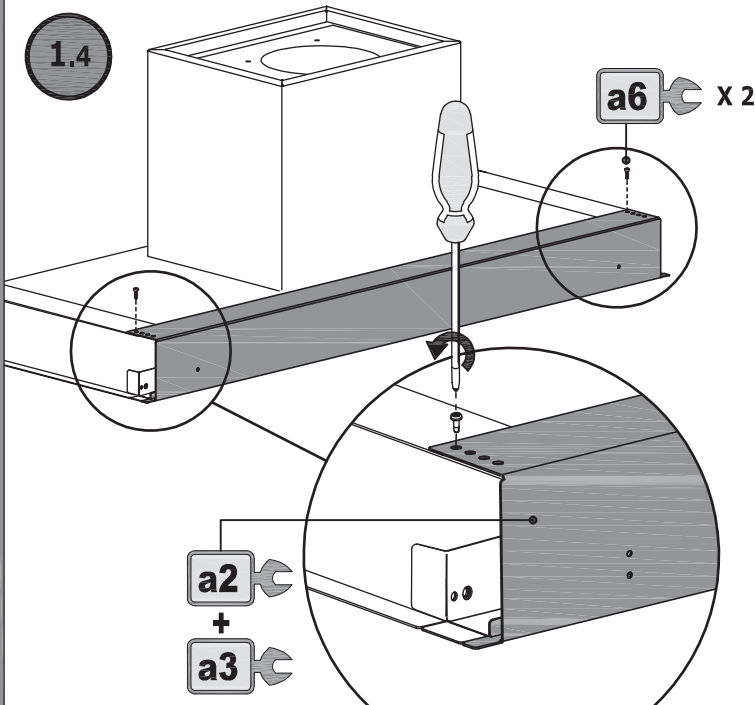

Dim. A :

310-320-330-340-350 mm

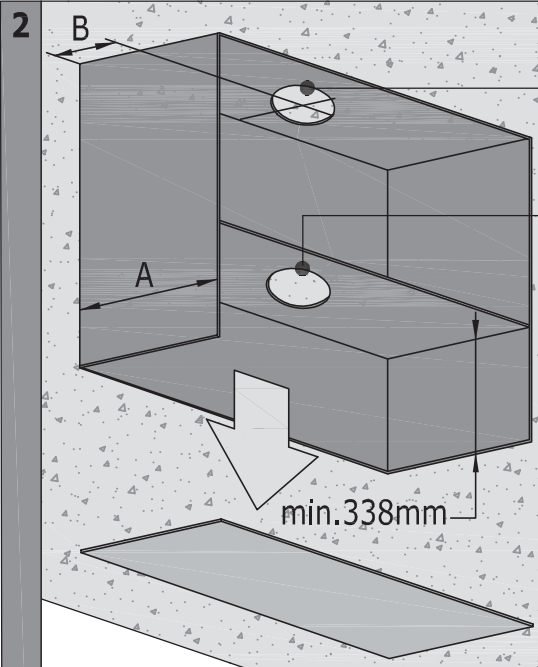
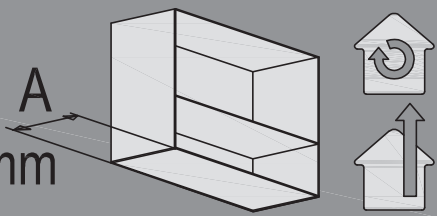

2.1

160mm
180mm

A	B
310	102.5
320	112.5
330	122.5
340	132.5
350	142.5

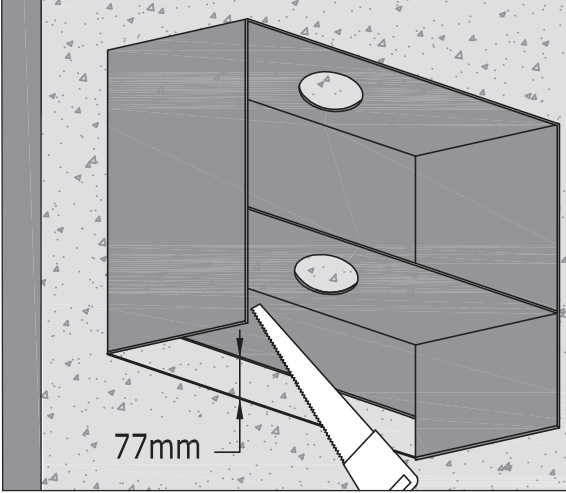

2.2

3

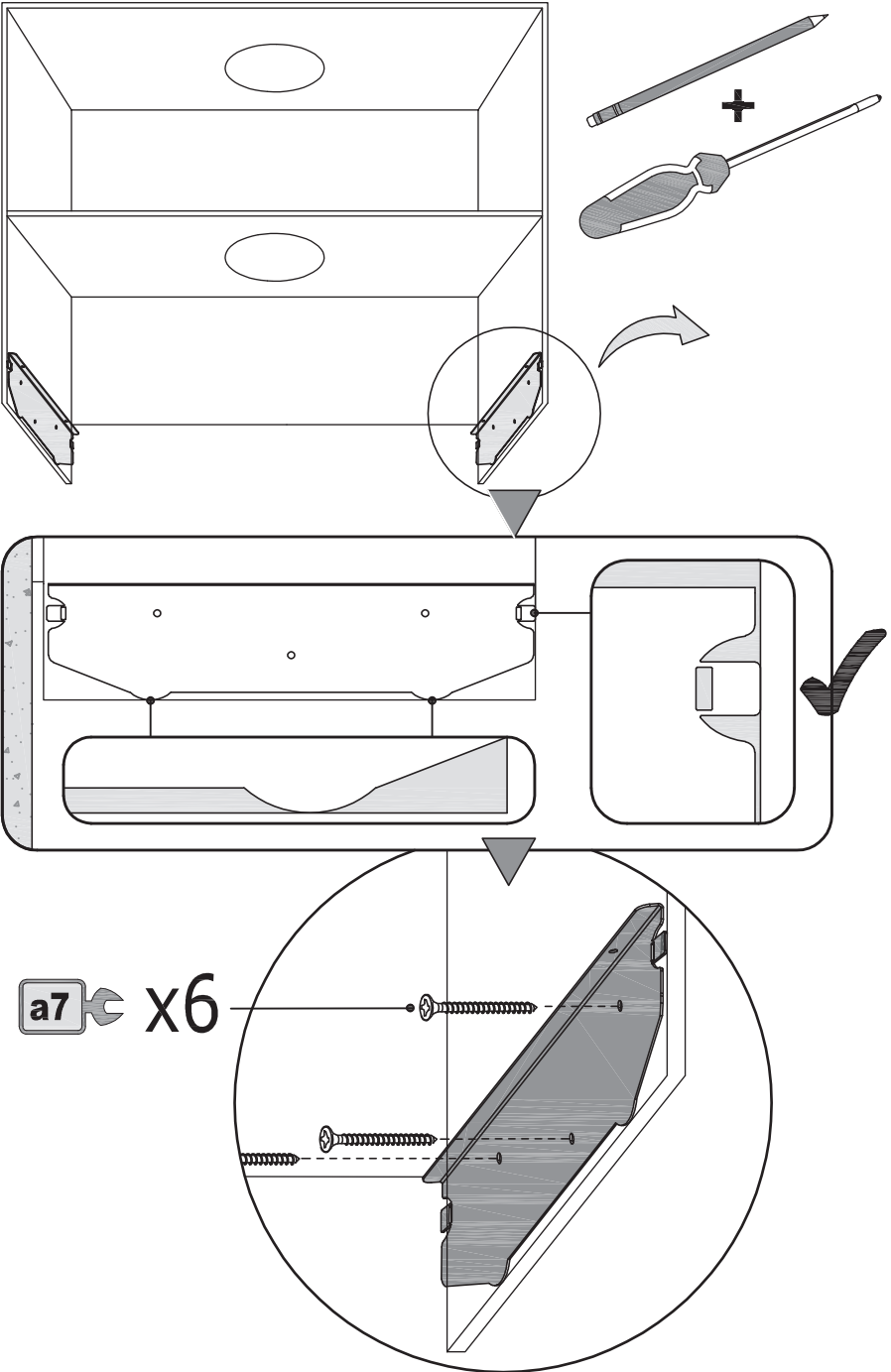

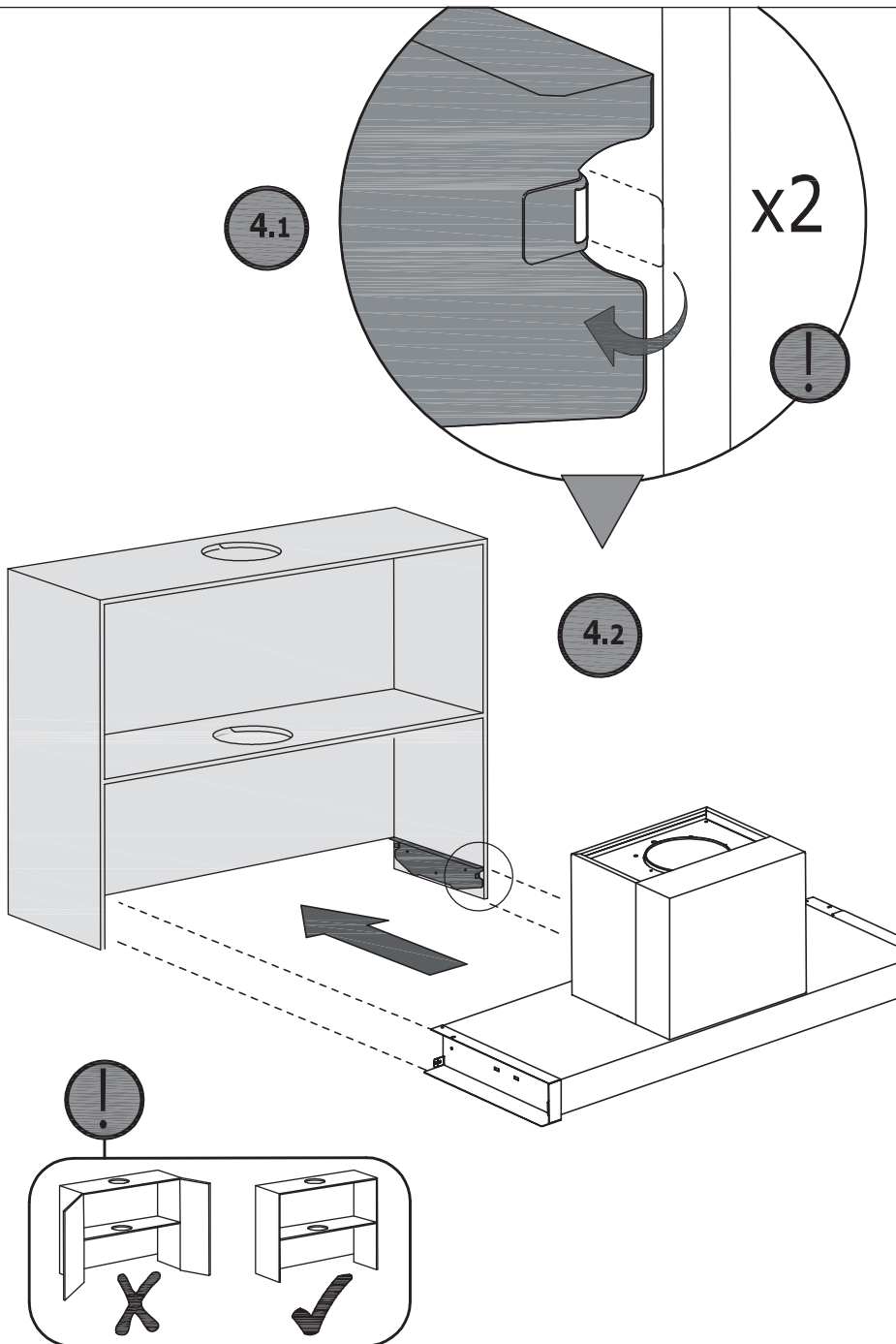

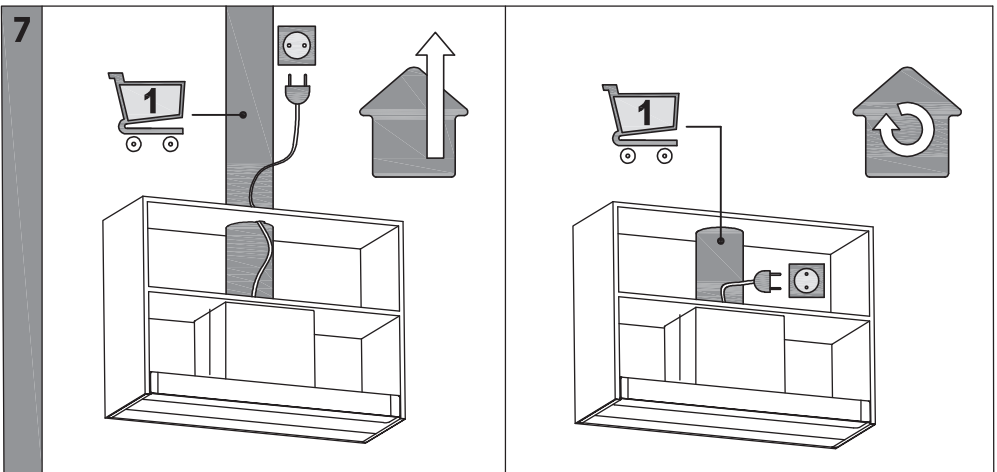
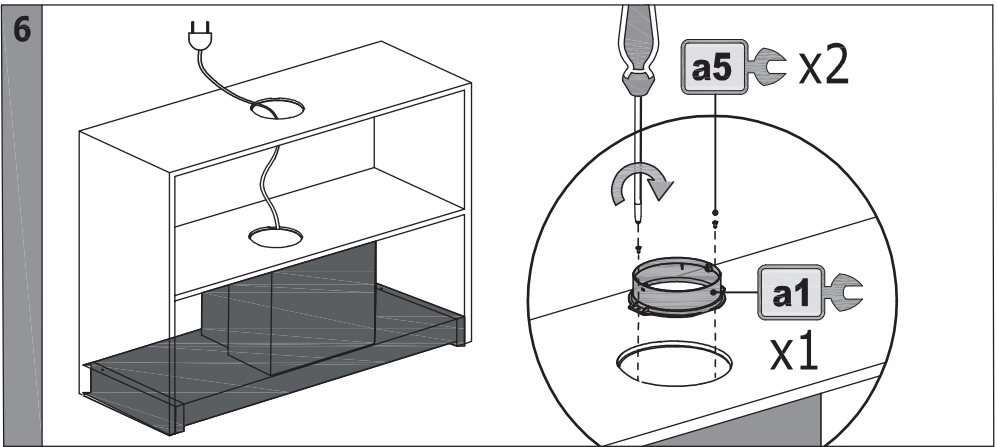
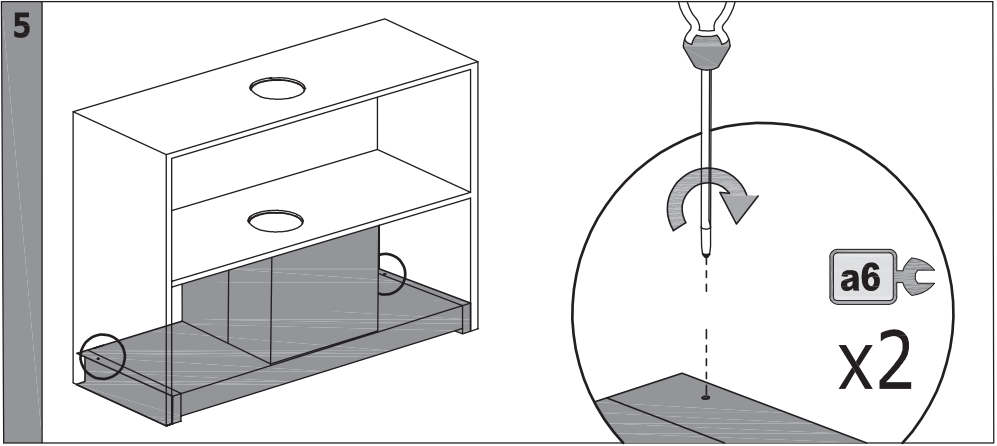



MANTENIMIENTO DE LA CAMPANA



Atención: corte siempre el suministro eléctrico antes de realizar el mantenimiento de la campana. En caso de avería, contacte a un distribuidor oficial o un agente autorizado.

Limpieza externa: use detergente líquido, no corrosivo y evite el uso de productos de limpieza abrasivos y disolventes.

No utilizar dispositivos de limpieza por alta presión o vapor.



Importante: aumente la frecuencia de limpieza/sustitución de filtros si la campana se usa más de 2 horas diarias. Utilice siempre filtros originales del fabricante.

Filtros de grasa

Para evitar posibles incendios límpielos rigurosamente una vez al mes o cuando el testigo indicador lo advierta. Para ello, desmonte los filtros y lávelos con agua caliente y detergente. No usar abrillantador. Si usa lavavajillas (podría ennegrecer las partes metálicas sin afectar a su capacidad funcional), disponga verticalmente los filtros para evitar que se depositen restos sólidos.

1 MES

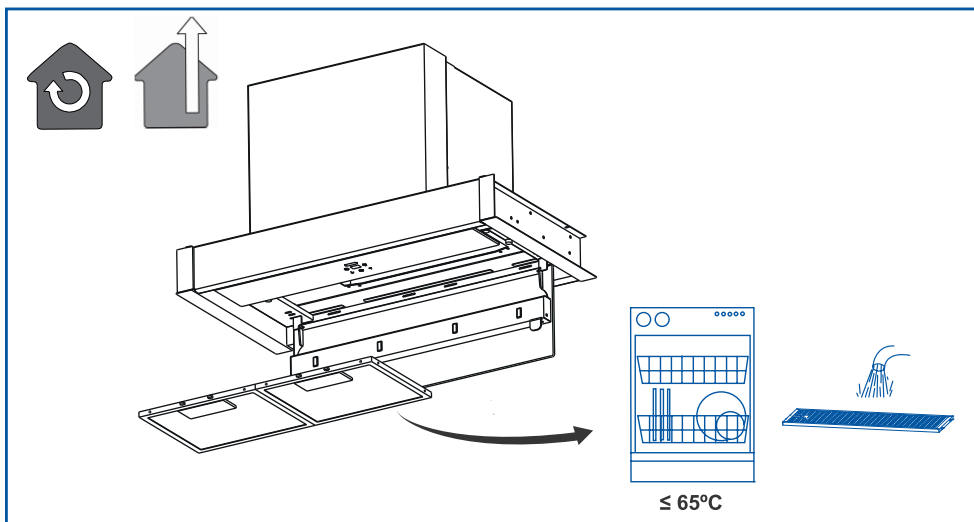



CARE & MAINTENANCE



Warning: always switch off the electricity supply before carrying out maintenance work on the hood. In the event of a fault, contact an official distributor or authorised dealer.

Cleaning the outside: use liquid, non-corrosive detergent and avoid using abrasive cleaning products and solvents. Do not use high-pressure or steam cleaning devices.



Important: increase the filter cleaning/replacement frequency if the hood is used for more than 2 hours a day. Always use genuine filters from the manufacturer.

Grease cleaning

To avoid fires, clean thoroughly once a month or whenever the display pilot light indicates as such. To do so, remove the filters and wash with hot water and detergent. If using a dishwasher (metal parts may turn black without this affecting their functional capacity), load the filters vertically to avoid solid residue from being deposited.

1 month

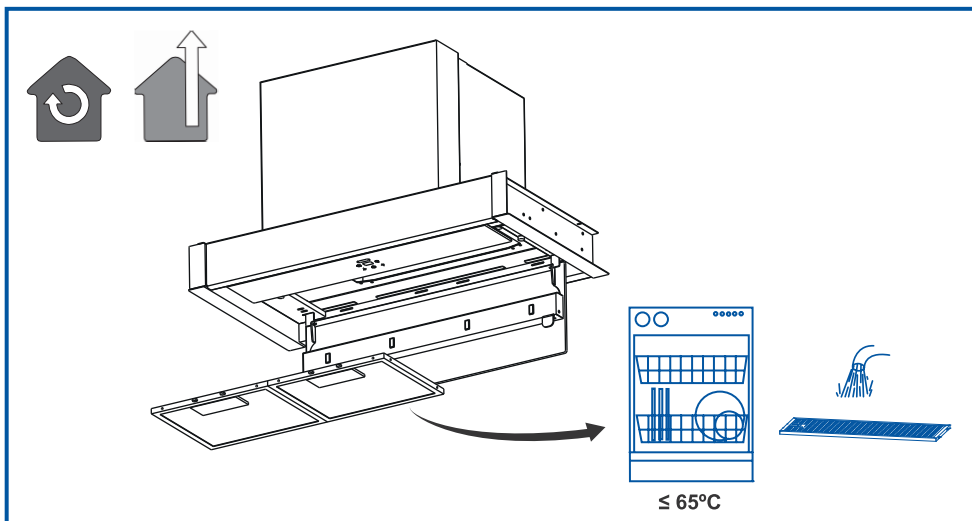



ENTRETIEN ET MAINTENANCE



Attention: coupez toujours l'alimentation électrique avant d'intervenir sur la hotte. En cas de défaut, contactez un distributeur officiel ou un agent agréé.

Nettoyage externe : utilisez du détergent liquide, non corrosif et évitez l'utilisation de produits de nettoyage abrasifs et de dissolvants. N'utilisez pas de dispositifs de nettoyage à haute pression ou à vapeur.



Important: Augmentez la fréquence de nettoyage / remplacement des filtres si la hotte est utilisée plus de 2 heures par jour. Utilisez toujours des filtres d'origine du fabricant.

Filtres à graisse

Il y a risque d'incendie si le nettoyage n'est pas effectué conformément aux instructions. Pour cela, démontez les filtres et lavez-les à l'eau chaude et avec du détergent neutre. Ne pas utiliser de liquide de rinçage. Si vous utilisez un lave-vaisselle (les pièces métalliques pourraient noircir sans que leur bon fonctionnement ne soit affecté), disposez les filtres à la verticale afin d'éviter le dépôt de résidus solides.

1 MOIS

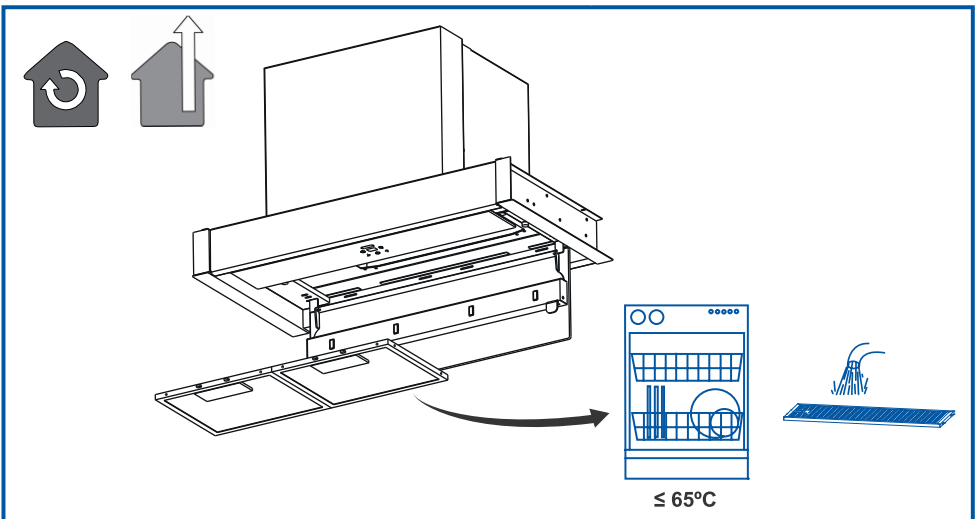



MANUTENÇÃO DO EXAUSTOR



Atenção: desligue sempre a corrente eléctrica antes de realizar a manutenção do exaustor. Em caso de avaria, contacte um distribuidor oficial ou um agente autorizado.

Limpeza exterior: utilize detergente líquido, não corrosivo e evite utilizar produtos de limpeza abrasivos e dissolventes.

Não utilize dispositivos de limpeza de alta pressão ou a vapor.



Importante: aumente a frequência de limpeza/substituição dos filtros se utiliza o exaustor mais do que 2 horas por dia. Utilize sempre os filtros originais do fabricante.

Filtros de gordura

para evitar possíveis incêndios, limpe-os rigorosamente uma vez por mês ou quando a luz de aviso indicar. Para isso, desmonte os filtros e lave-os com água quente e detergente.

Se utilizar a máquina de lavar loiça (pode escurecer as partes metálicas sem afetar a sua capacidade funcional), coloque verticalmente os filtros para evitar a acumulação de resíduos sólidos.

1 MÊS

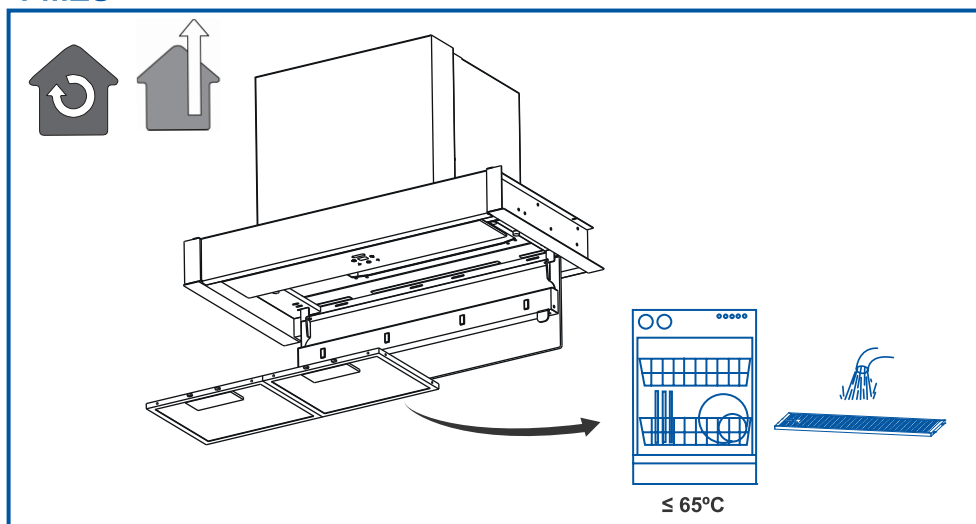



PFLEGE UND WARTUNG



Warnung: Schalten Sie vor Wartungsarbeiten an der Kapuze. Wenden Sie sich im Falle einer Störung an einen Vertragshändler oder eine Vertragsfirma.

Reinigung der Außenseite: Verwenden Sie ein flüssiges, nicht korrosives Reinigungsmittel und vermeiden Sie die Verwendung von Scheuermitteln. Verwenden Sie keine Hochdruck- oder Dampfreinigungsgeräte.



Wichtig: Erhöhen Sie die Häufigkeit der Filterreinigung/des Filterwechsels, wenn die Haube für mehr als 2 Stunden am Tag. Verwenden Sie immer Originalfilter des Herstellers.

Reinigung mit Fett

Um Brände zu vermeiden, reinigen Sie einmal im Monat oder immer dann, wenn die Kontrollleuchte des Displays solche. Entfernen Sie dazu die Filter und waschen Sie sie mit heißem Wasser und Reinigungsmittel. Bei Verwendung einer Spülmaschine (Metallteile können sich schwarz verfärben, ohne dass dies ihre Funktionsfähigkeit beeinträchtigt), die Filter vertikal, um die Ablagerung von festen Rückständen zu vermeiden.

1 MONAT

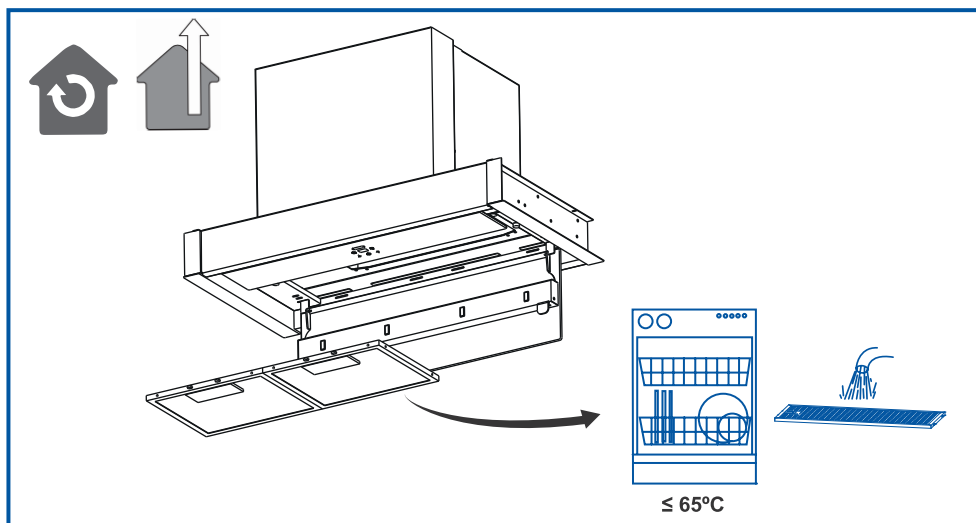



CNA
group

CATA ELECTRODOMÉSTICOS, S.L.

Oficinas: c/ Anabel Segura, 11, Edif. A, 3a pl. 28108. Alcobendas. Madrid. España

Fábrica: c/ del Ter 2, Apdo. 9. 08570. Torelló. Barcelona. España

T . +34 938 594 100 - Fax +34 938 594 101

www.cnagroup.es - cna@cnagroup.es

Atención al Cliente: 902 410 450 / +34 938 521 818 - info@cnagroup.es

SAT Central Portugal: +351 214 349 771 - service@junis.pt

60819285.30.03.2020