

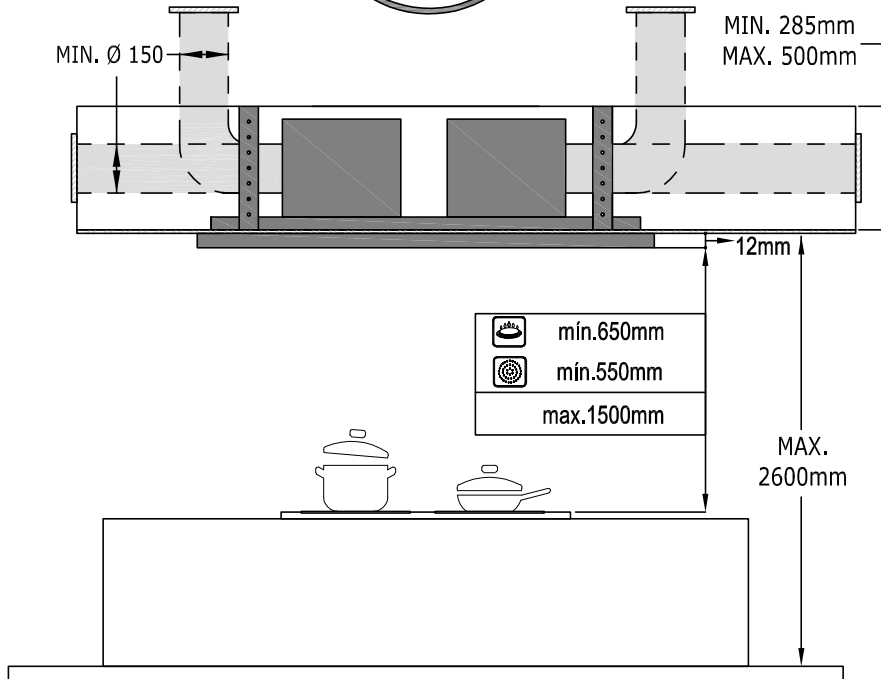

- ES** MANUAL DE INSTALACIÓN
- EN** INSTRUCCIONS FOR INSTALLATION
- FR** MANUEL D'INSTALLATION
- PT** MANUAL DE INSTALAÇÃO
- DE** MONTAGEANLEITUNG

 **NODOR**  
*always innovating*



**ES - ADVERTENCIA:**

- Todo el trabajo de instalación debe llevarse a cabo por una persona bien calificada que siga estrictamente las normativas de construcción locales y estas instrucciones.
- Utilice únicamente accesorios y tornillos de montaje del mismo tamaño, como se recomienda en este manual de instrucciones.
- El fabricante se exime de toda responsabilidad por daños personales o materiales que se puedan causar como resultado del uso inadecuado o la instalación incorrecta de este aparato.

**EN - WARNING:**

- All installation work must be carried out by a suitably qualified person, strictly following local building regulations and these instructions.
- Use only the same size of fittings and mounting screws as recommended in this instruction manual.
- The manufacturer declines all liability for personal or material damage as a result of misuse or incorrect installation of this appliance.

**FR - AVERTISSEMENT:**

- Toutes les installations doivent être effectuées par une personne dûment qualifiée, en suivant rigoureusement les instructions du fabricant.
- N'utiliser que des raccords et des vis de fixation de même taille tels que recommandés dans ce manuel d'instructions.
- Le fabricant décline toute responsabilité en cas de dommages personnels ou matériels en cas de mauvaise utilisation ou de mauvaise installation de cet appareil.

**PT - AVISO:**

- Todo o trabalho de instalação deve ser efetuado por uma pessoa devidamente qualificada, seguindo rigorosamente os regulamentos locais de construção e estas instruções.
- Utilize apenas suportes e parafusos de fixação com o tamanho recomendado neste manual de instruções.
- O fabricante está isento de qualquer responsabilidade por danos pessoais ou materiais resultantes da utilização indevida.

**DE - WARNUNG:**

- Alle Installationsarbeiten müssen von einer entsprechend qualifizierten Person, streng nach den örtlichen Gebäudevorschriften und gemäß diesen Anweisungen durchgeführt werden.
- Verwenden Sie nur Befestigungsmaterial und -schrauben, wie in der Bedienungsanleitung empfohlen.
- Der Hersteller lehnt jede Haftung für Personen- oder Sachschäden ab aufgrund von Missbrauch oder falscher Installation dieses Geräts.

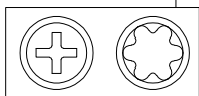
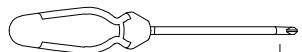

Ø 8

PH 2

T15

T20

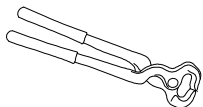
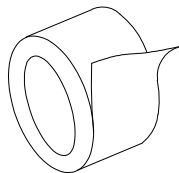
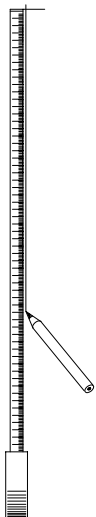
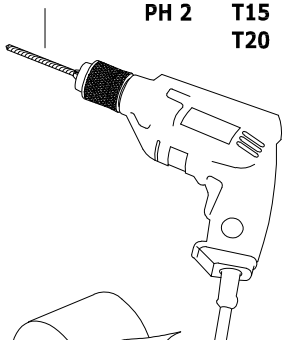

**a1** X 6



Ø8 x 50

**a6** X 4



Ø3.5 x 9.5

T15

**a2** X 6



Ø4.5 x 60

PH 2

**a7** X 2

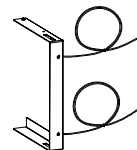

**a3** X 16



Ø4 x 6

T20

**a8** X 4



M6.4 x 1.8

**a4** X 2



Ø150  
x550

**a9** X 4



Ø4 x 60

PH 2

**a5** X 2



**a10** X 2

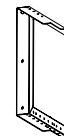

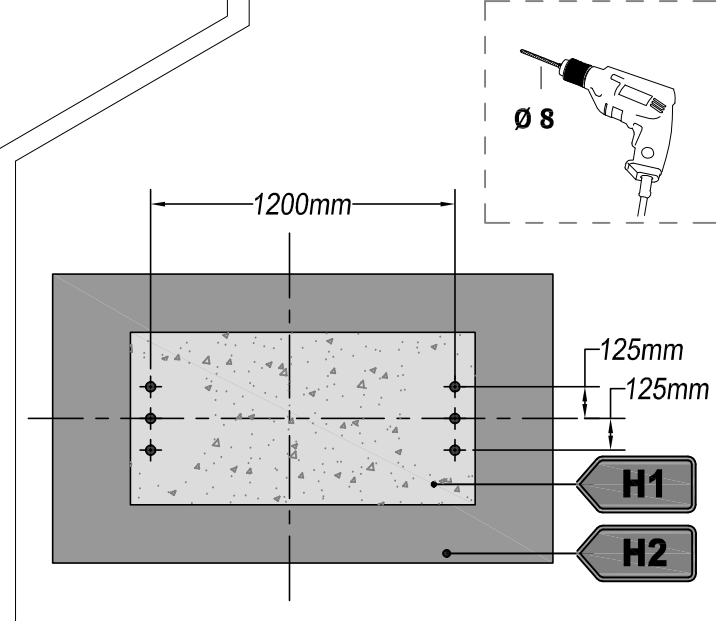
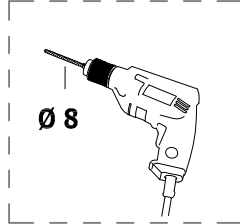
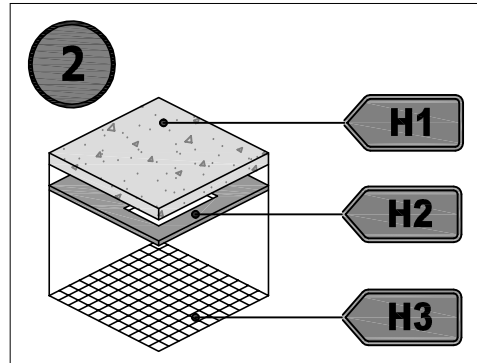
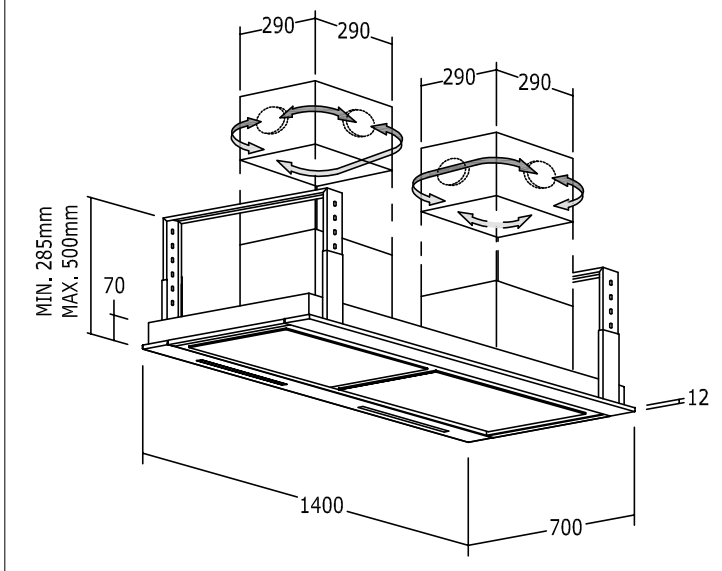
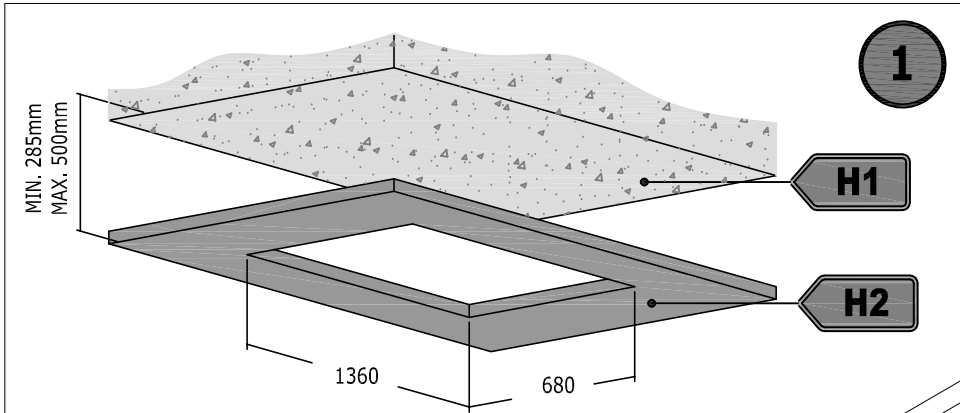

3

a10

a7

MAX: 83mm  
MIN: 58mm

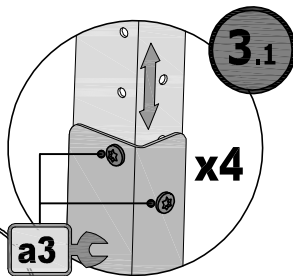

3.1 x2

a3

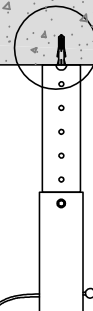

3.2 x2

a1

a2

x3

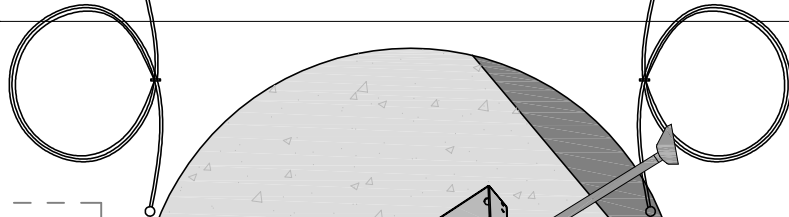

3.1 x8

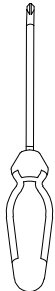
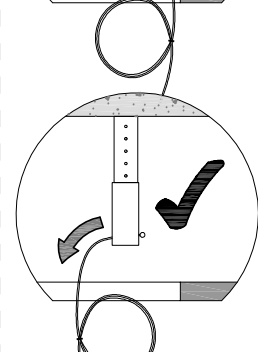
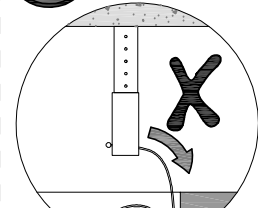

a1

x 6

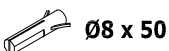

a2

x 6



a3

x 8

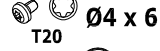

a7

x 2

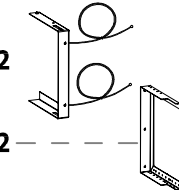

a10

x 2

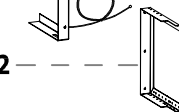

3.2 x6

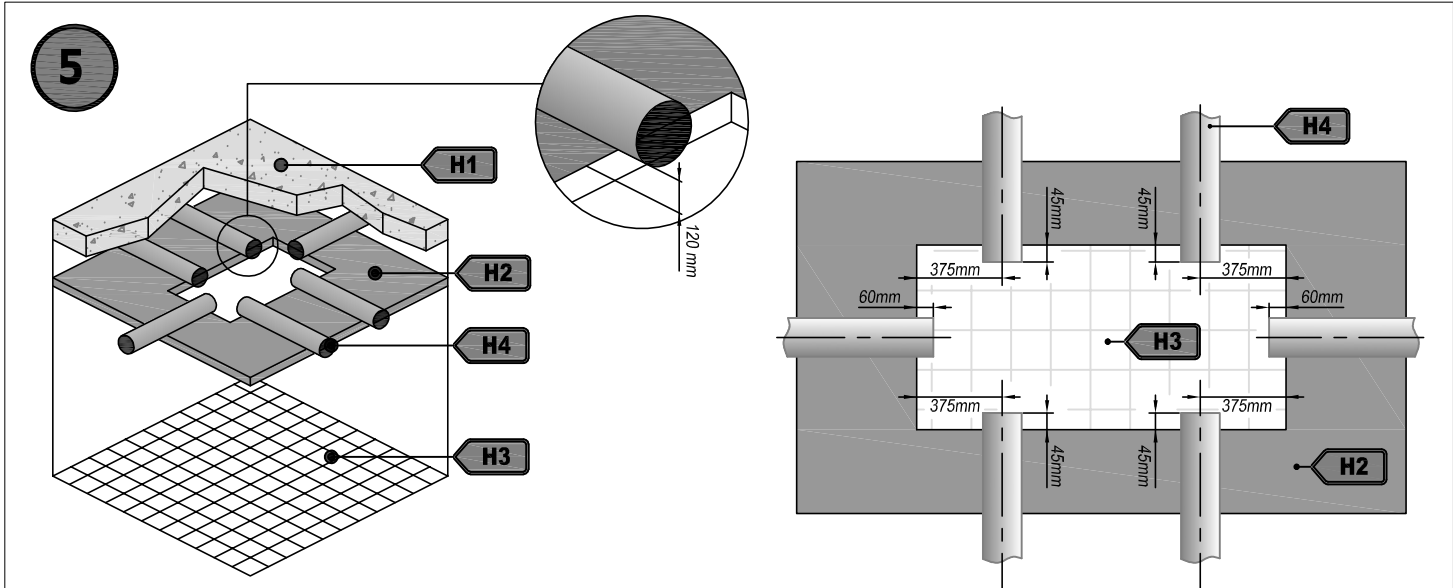
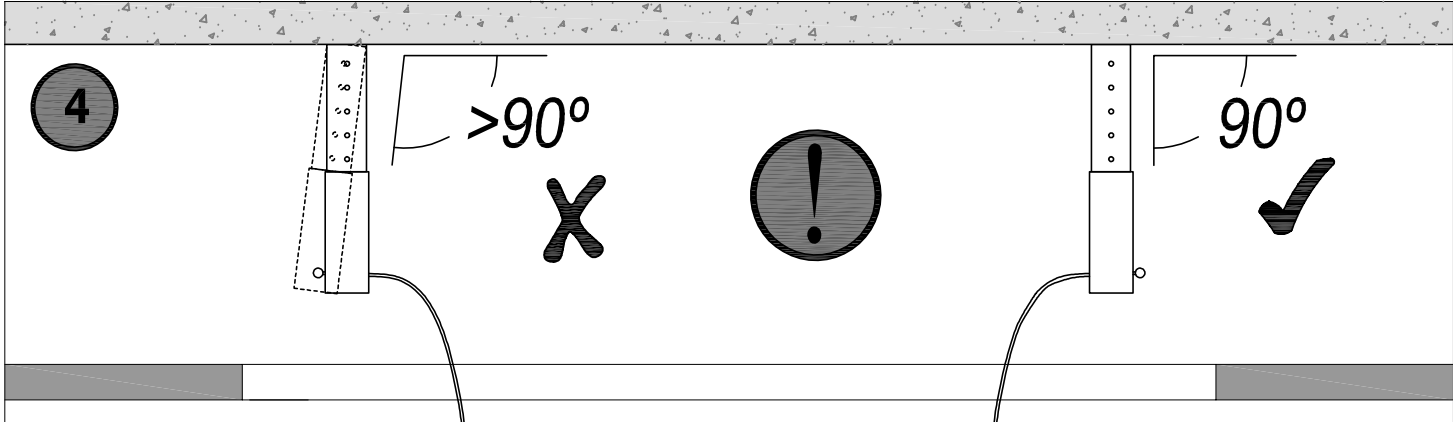



I

II

III

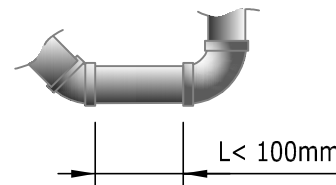
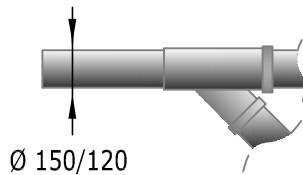
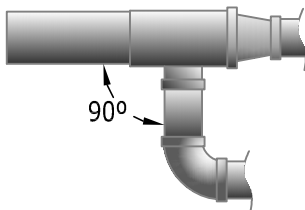
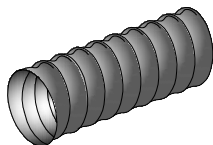
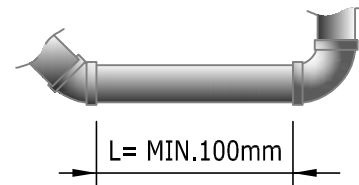
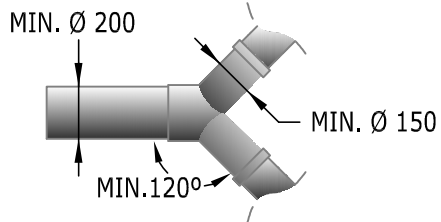
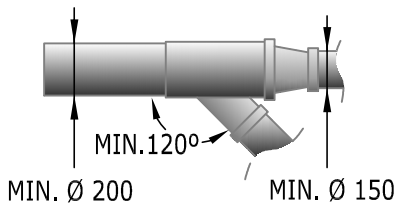
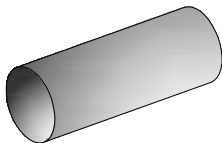

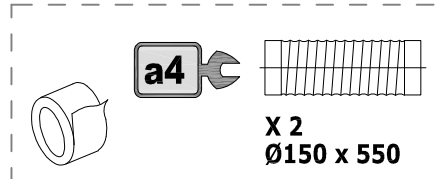
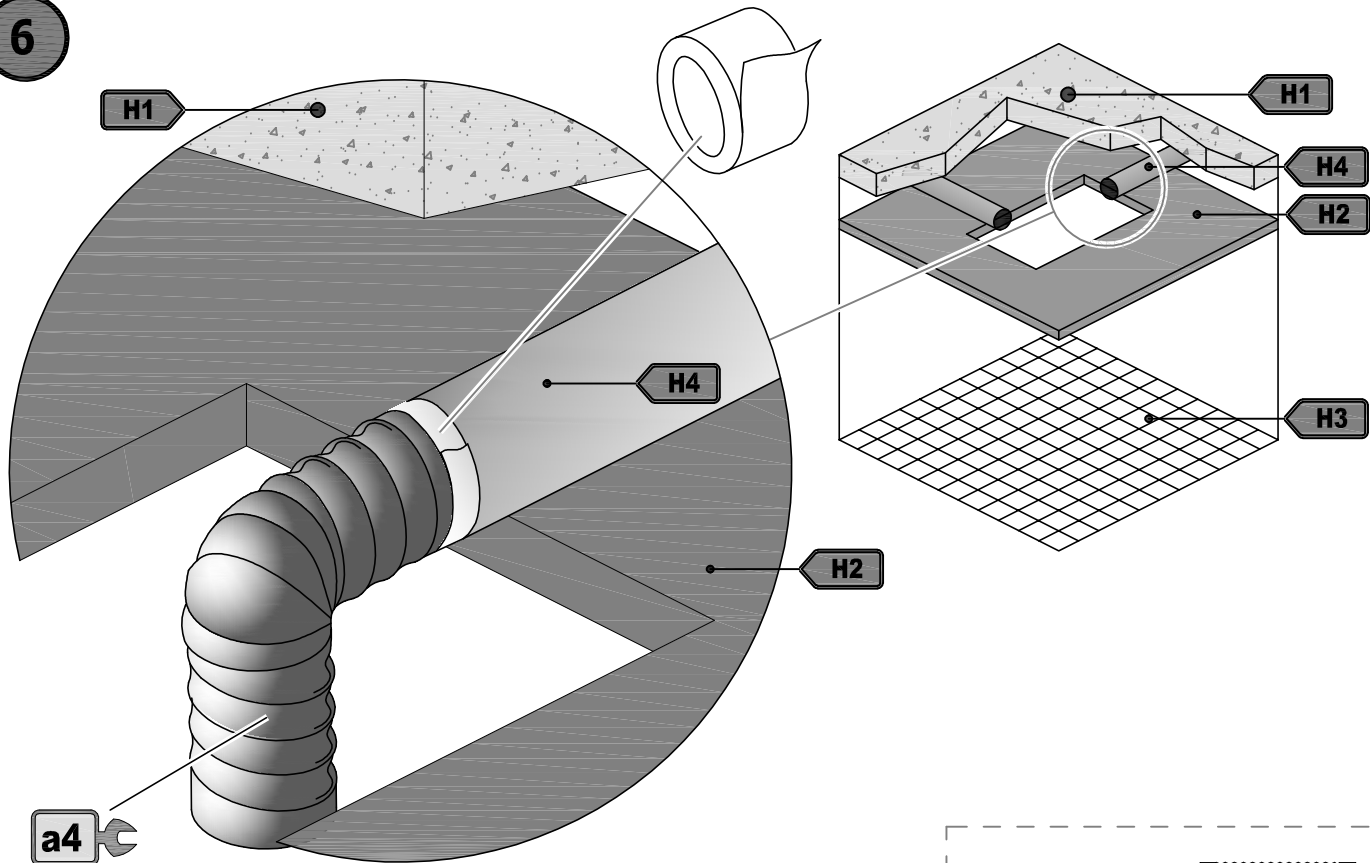

6





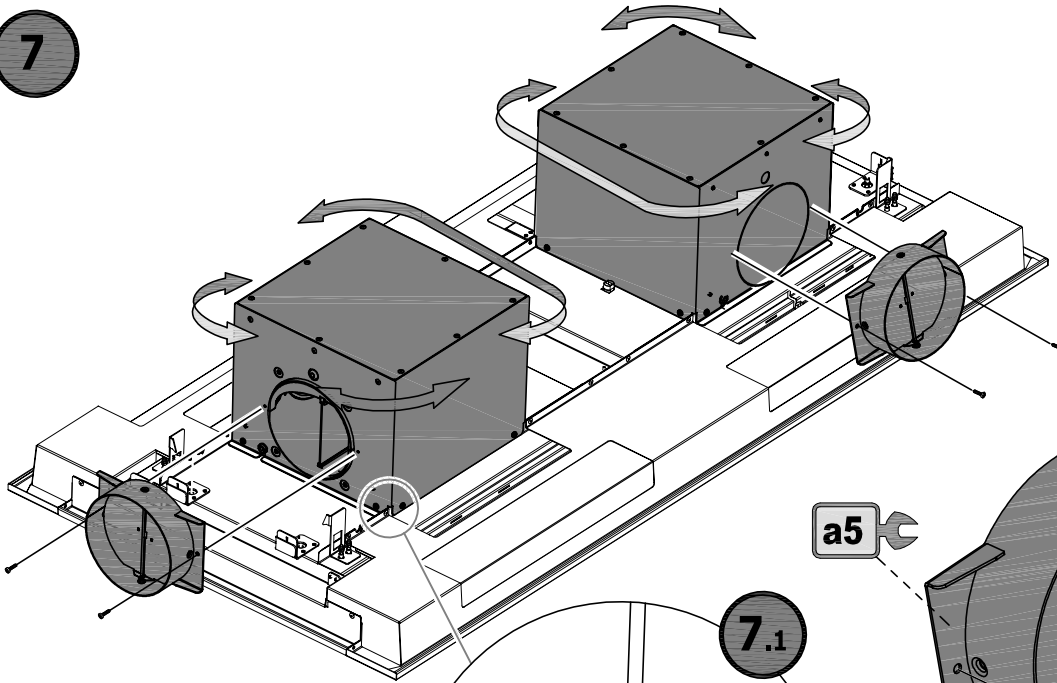

7

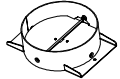

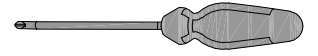

a5 X 2  

a6 X 4   T15  
Ø3.5 x 9.5



7.2

a6  

a5 

7.1

16x  T20

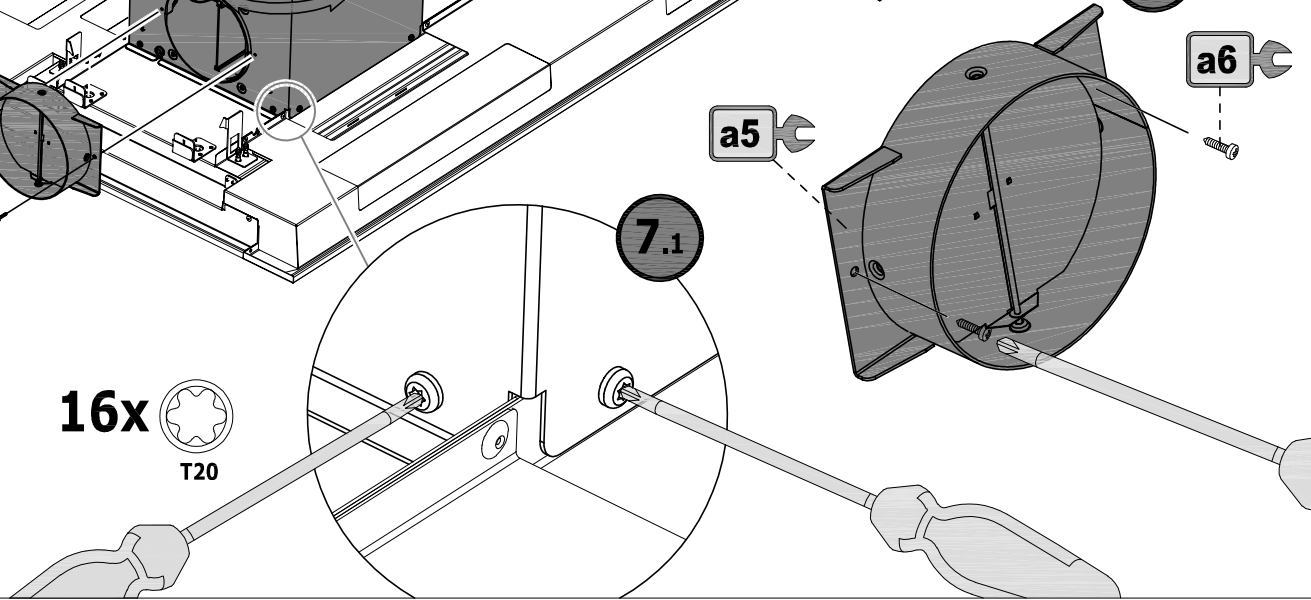

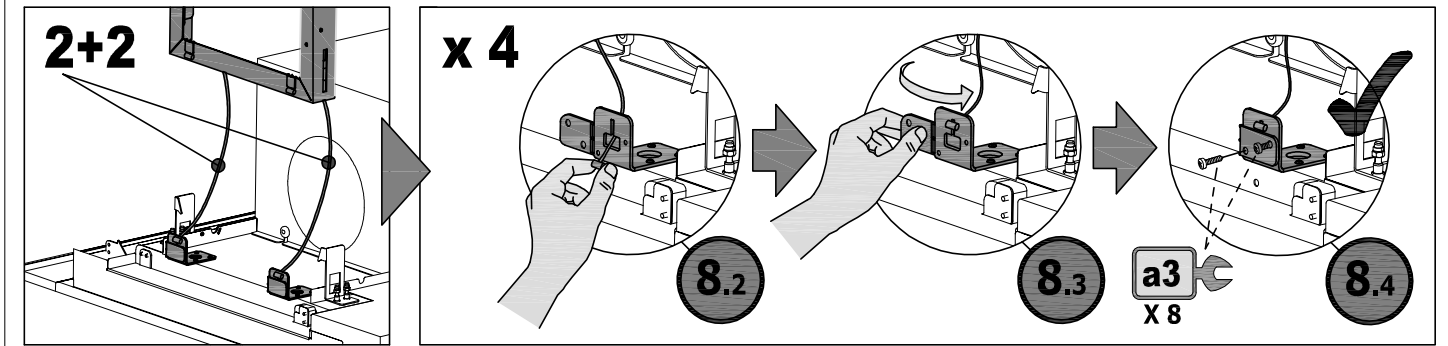
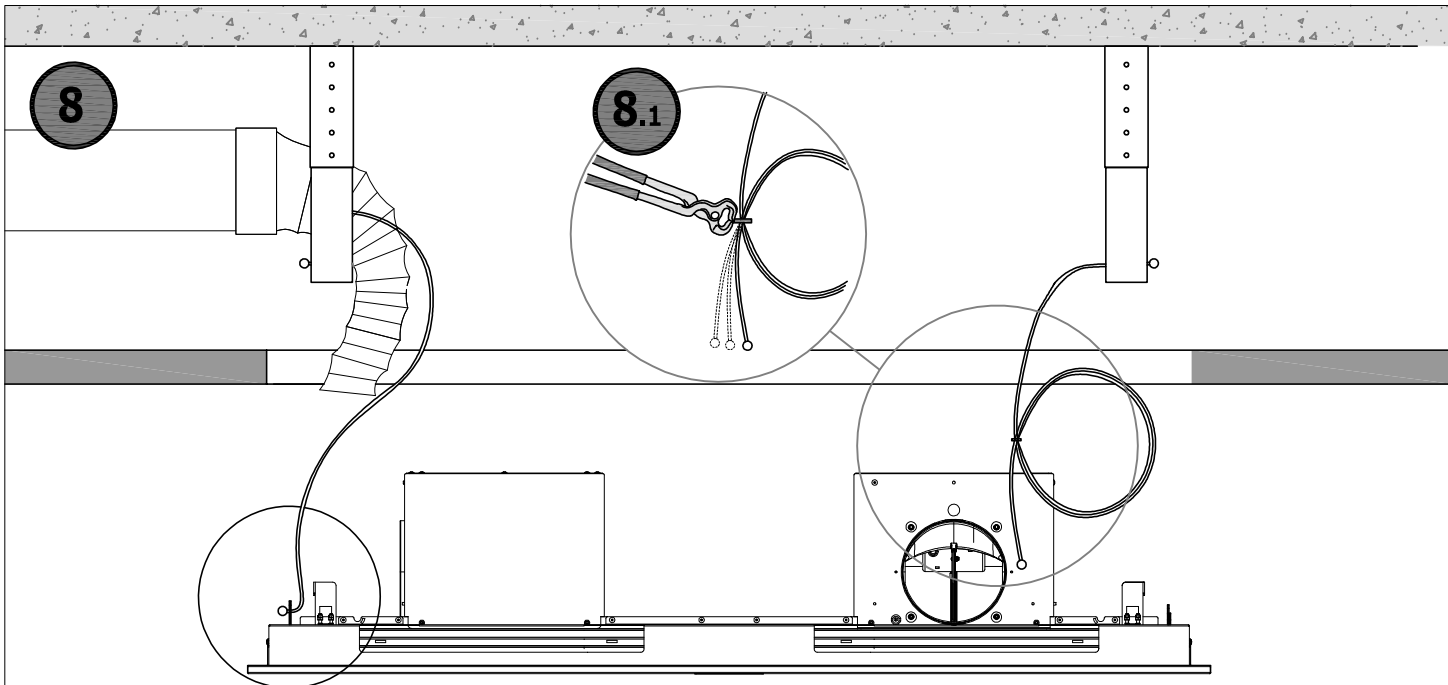

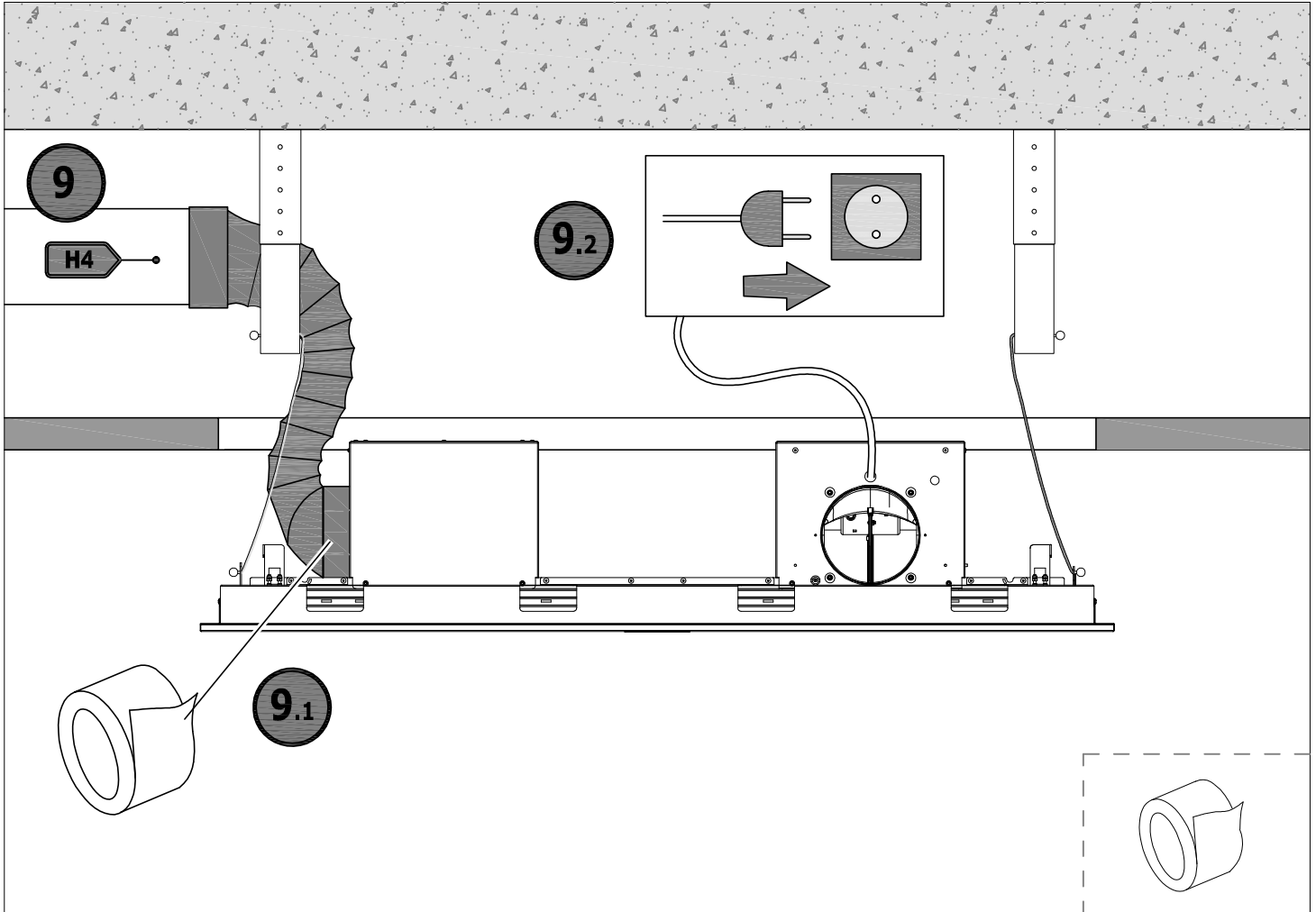

10

click

click



x 4

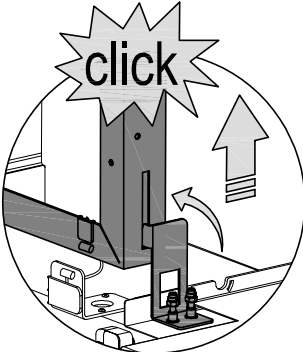
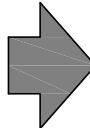
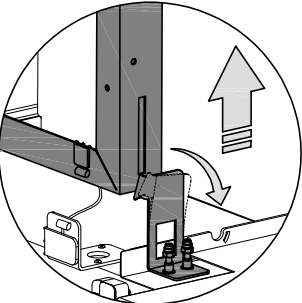
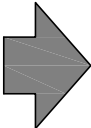
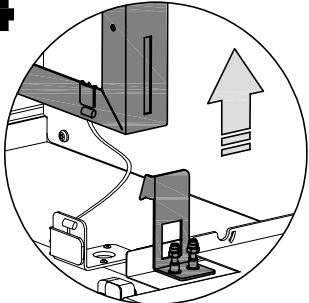

11

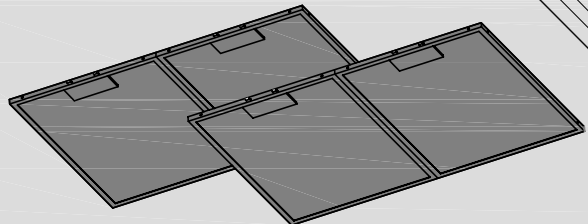
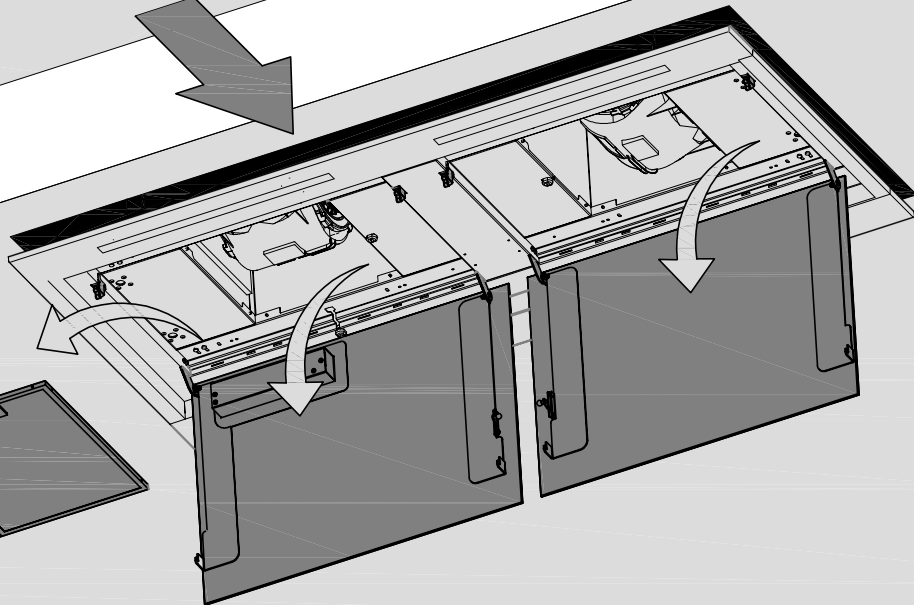
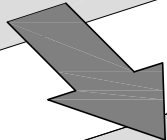
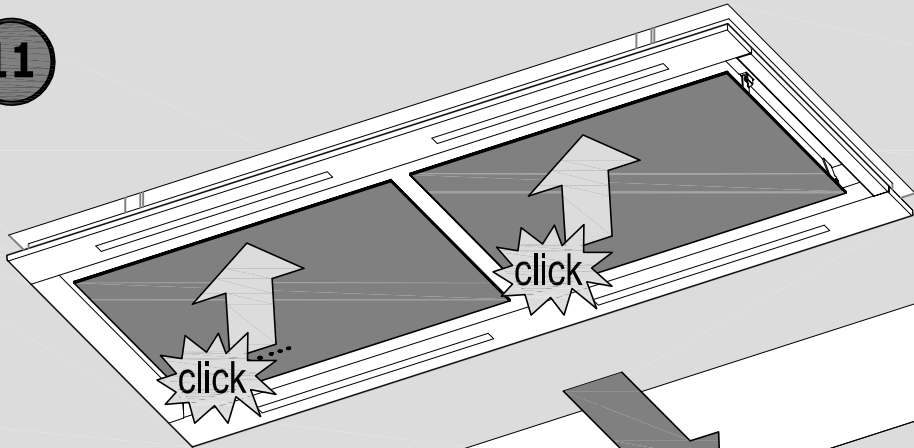

x 4

12

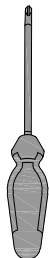
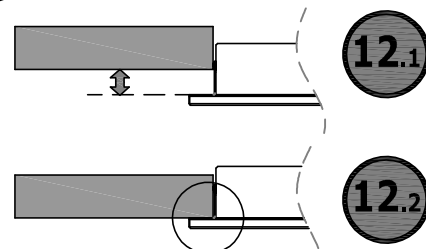
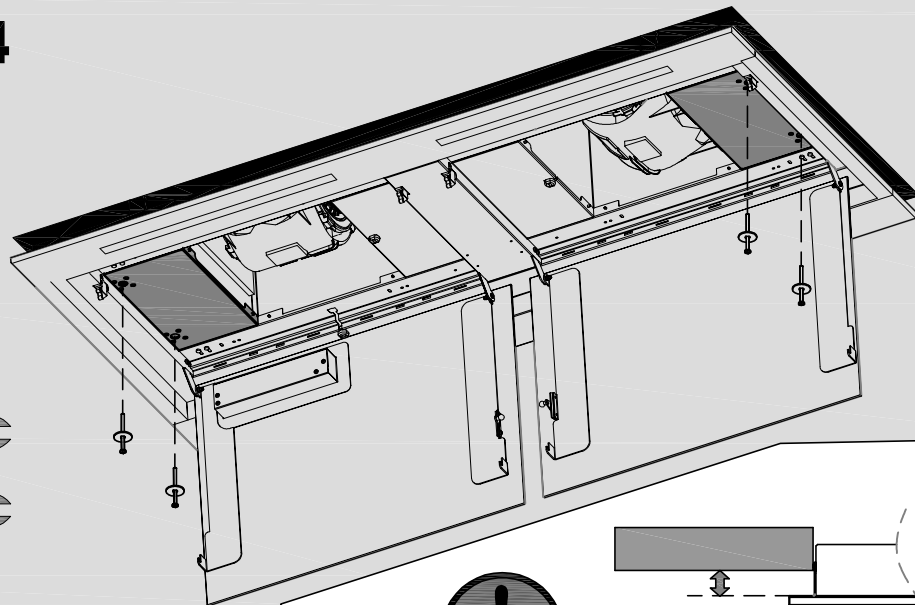
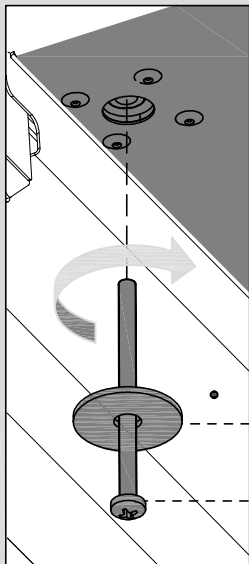

M6.4 x 1.8



Ø4 x 60

PH 2

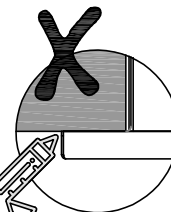
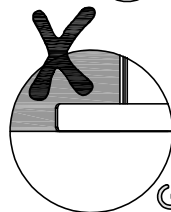
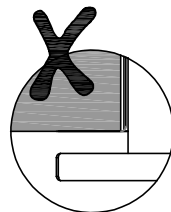
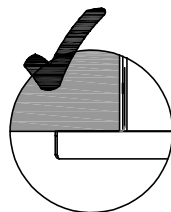

13

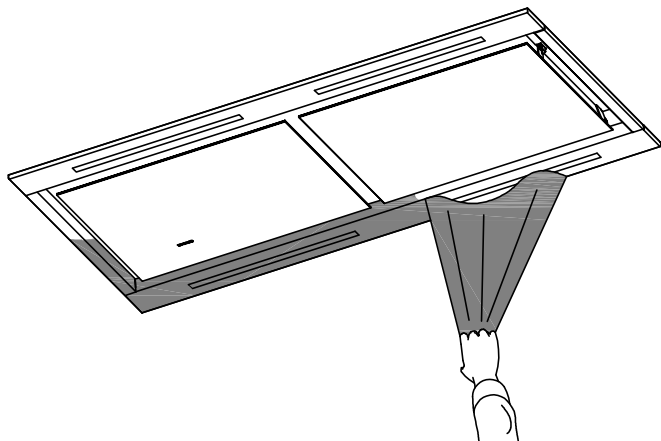

ES - Limpieza del filtro de grasa  
EN - Cleaning the grease filter  
FR - Nettoyage du filtre de graisse  
PT - Limpeza do filtro de gordura  
DE - Reinigung des Fettfilters

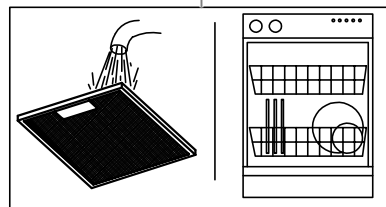
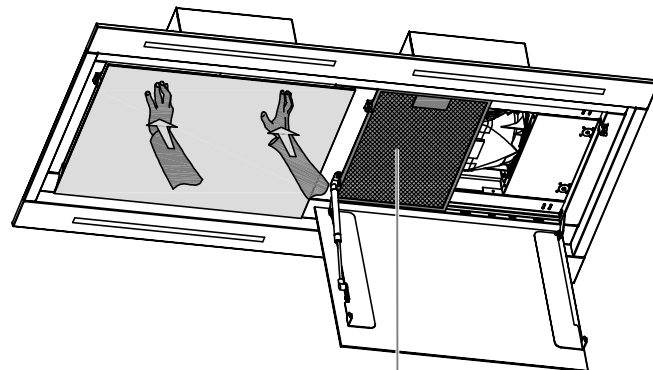



CNA  
group

**CATA ELECTRODOMÉSTICOS, S.L.**

**Oficinas:** c/ Anabel Segura, 11, Edif. A, 3a pl. 28108. Alcobendas. Madrid. España

**Fábrica:** c/ del Ter 2, Apdo. 9. 08570. Torelló. Barcelona. España

T . +34 938 594 100 - Fax +34 938 594 101

[www.cnagroup.es](http://www.cnagroup.es) - [cna@cnagroup.es](mailto:cna@cnagroup.es)

**Atención al Cliente:** 902 410 450 / +34 938 521 818 - [info@cnagroup.es](mailto:info@cnagroup.es)

**SAT Central Portugal:** +351 214 349 771 - [service@junis.pt](mailto:service@junis.pt)