

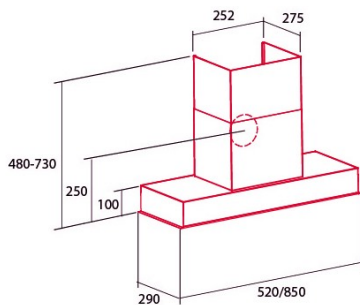

NorBreeze CUDO 850 SS

Cod. 8355

EAN 8435025783553



GENERAL INFORMATION

EAN/UPC	8435025783553
Subfamily	Insert

Product sheet according to directives EU65/2014 - EN61591, EN60704-2-13, EN50564

AEC (Annual energy consumption) (kWh/year)	44
EI class (energy efficiency class)	A
FDE (fluid dynamic efficiency)	31,9
FDE class (fluid dynamic efficiency class)	A
LE (light efficiency) (lux/W)	32
LE class (light efficiency class)	A
GFE (grease filtering efficiency)	97,1
GFE class (grease filtering efficiency class)	A
Airflow in normal mode MIN (m3/h)	235
Airflow in normal mode MAX (m3/h)	433
Airflow in boost mode MIN (m3/h)	655
Acoustic power in normal mode MIN (dB)	59
Acoustic power in normal mode MAX (dB)	65
Acoustic power boost mode (dB)	70
Po (energy consumption in off mode) (W)	0
Ps (energy consumption in standby mode) (W)	0,49

Integration directive EU 66/2014

f (time increase factor)	0,9
EI (Energy Efficiency Index)	50,9
QBEP (maximum efficiency at air flow point) (m3/h)	315,3
PBEP (maximum efficiency at pressure point) (Pa)	457
WBEP (power consumption at maximum efficiency) (W)	125,5
WL (nominal power lighting system) (W)	3,8
EMIDDLE (Average illuminance on the cooking surface) (lux)	120

External Dimensions

Width (mm)	831
Depth (mm)	265
Diamètre de sortie (mm)	150

Characteristics

Motor quantity	1
Maximum pressure (Pa)	503
Control technology	Mechanical push button
Booster	√
Power levels	4
Timer	√
Filter saturation indicator	-
Charcoal filter replacement indicator	-
Dimmer function	√
Connectivity	No
Remote control	-
Display	-

Lighting

Ray technology	LED
----------------	-----

Installation

Back draught shutter	Included
----------------------	----------

Electric connection

Nominal voltage (V)	220-240
Nominal frequency (Hz)	50/60
Plug type	Type F

Accessories

Upper decorative duct extension	STANDARD CIMNEYS IN THE PRODUCT
Back draught shutter	STANDARD IN THE MOTOR
Activated charcoal filter	N°2 KF8 (384X193,5X9)

