

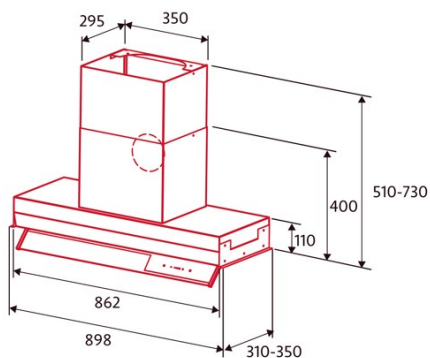

## NorBreeze BISE 900 SS

Cod. 8353

EAN 8435025783539



### GENERAL INFORMATION

EAN/UPC	8435025783539
Subfamily	Integrated

### Product sheet according to directives EU65/2014 - EN61591, EN60704-2-13, EN50564

AEC (Annual energy consumption) (kWh/year)	42,9
EI class (energy efficiency class)	A
FDE (fluid dynamic efficiency)	34,5
FDE class (fluid dynamic efficiency class)	A
LE (light efficiency) (lux/W)	28,7
LE class (light efficiency class)	A
GFE (grease filtering efficiency)	91,8
GFE class (grease filtering efficiency class)	B
Airflow in normal mode MIN (m3/h)	265
Airflow in normal mode MAX (m3/h)	610
Airflow in boost mode MIN (m3/h)	735
Acoustic power in normal mode MIN (dB)	44
Acoustic power in normal mode MAX (dB)	63
Acoustic power boost mode (dB)	71
Po (energy consumption in off mode) (W)	0
Ps (energy consumption in standby mode) (W)	0,49

### Integration directive EU 66/2014

f (time increase factor)	0,8
EI (Energy Efficiency Index)	47
QBEP (maximum efficiency at air flow point) (m3/h)	346,5
PBEP (maximum efficiency at pressure point) (Pa)	474
WBEP (power consumption at maximum efficiency) (W)	132
WL (nominal power lighting system) (W)	6
EMIDDLE (Average illuminance on the cooking surface) (lux)	172

### External Dimensions

Width (mm)	862
Depth (mm)	310
Maximum total height (mm)	730
Minimum total height (mm)	510
Diamètre de sortie (mm)	150

### Characteristics

Motor quantity	1
Maximum pressure (Pa)	541
Control technology	Electronic Touch Control
Booster	√
Power levels	4
Timer	√
Filter saturation indicator	-
Charcoal filter replacement indicator	-
Dimmer function	-
Connectivity	No
Remote control	-

### Lighting

Ray technology	LED
----------------	-----

### Installation

Minimum distance to electric plate (mm)	650
Minimum distance to gas plate (mm)	650
Charcoal filter	-
Back draught shutter	Included

### Electric connection

Nominal voltage (V)	220-240
Nominal frequency (Hz)	50/60
Electric shock protection	Class II
Plug type	Type F

### Accessories

Upper decorative duct extension	STANDARD CIMNEYS IN THE PRODUCT
Back draught shutter	STANDARD IN THE MOTOR
Activated charcoal filter	N°2 HP8 (384x193,4x9,5)