



NorChef MO 4800 CU

Cod. 2127

EAN 8435025721272

2115_NorChef MO 4800 DB
2119_NorChef MO 4800 SW
2127_NorChef MO 4800 CU
2129_NorChef MO 4800 SS

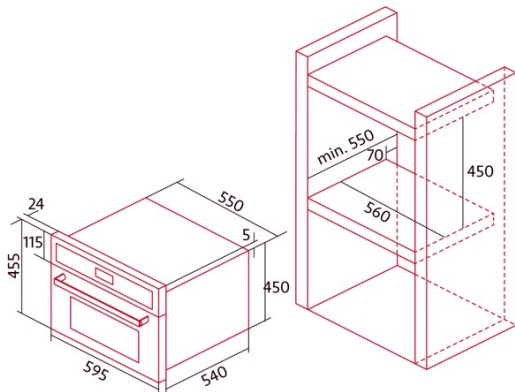

GENERAL INFORMATION

EAN/UPC	8435025721272
Subfamily	Compact

Product sheet

Energy Efficiency Index (EEI)	92,3
Energy efficiency class	A
Energy consumption in conventional mode (kWh/cycle)	0,69
Energy consumption in fan mode (kWh/cycle)	0,67
Heat source	Electricity
Appliance mass [Kg]	26,65
Number of cavities	1
Cavity volume (L)	40

Dimensions

Width (mm)	595
Height (mm)	455
Depth (mm)	550
Built-in width (mm)	595
Built-in height (mm)	455
Built-in depth (mm)	550

Controls

Control type	Touch control
Display	LCD
Number of functions	8
Functions	Light;Turbo heating;Top heating;Top and bottom heating;Defrosting;Fast preheat;3D cooking;Top and bottom heating with fan;Double Grill
Timer	Electronic
On/off indicator	√
Thermostat indicator	√
Minimum temperature [°C]	50
Maximum temperature [°C]	225
Thermal probe	-

Characteristics

Enamel	Easy cleaning Nclean enamel
Drop down grill	-
Removable inner glass	√
Number of light bulbs	15
Bulb power [W]	1
Number of door glasses	2
Manual door lock	-
Soft close	-
Cavity type	Flat
Side racks	√
Levels	4
Telescopic guides	0,75
Convection fan	√

Safety

Cooling fan	√
Overheating protection	√
Automatic safety shutdown	-
Pyrolysis door lock	-
Pyrolysis lock indicator	-

Electrical connection

Power of the upper heating element [W]	Commercial sheet
Lower power of the heating element [W]	1050
Turbocharger power [W]	1600
Nominal voltage (V)	220-240
Nominal frequency (Hz)	50
Nominal input power (W)	3280
Electric shock protection	Class I
Power cord length (m)	1,2
Plug type	No plug

Accessories

Flat tray	-
Deep tray	√
Steam tray	-
Grill	√
Inner grill	√
Telescopic guides	√
Tray handle	√
Removable tank	-
Pizza stone	-
Roast kit	-